



# CATALOG OF REPLACEMENT PARTS

## MODEL A200 & A200T SERIES MIXER

(INCLUDES MOTOR PARTS)

ML-104567	A200
ML-104568	A200T
ML-104569	A200DT
ML-104570	A200FT



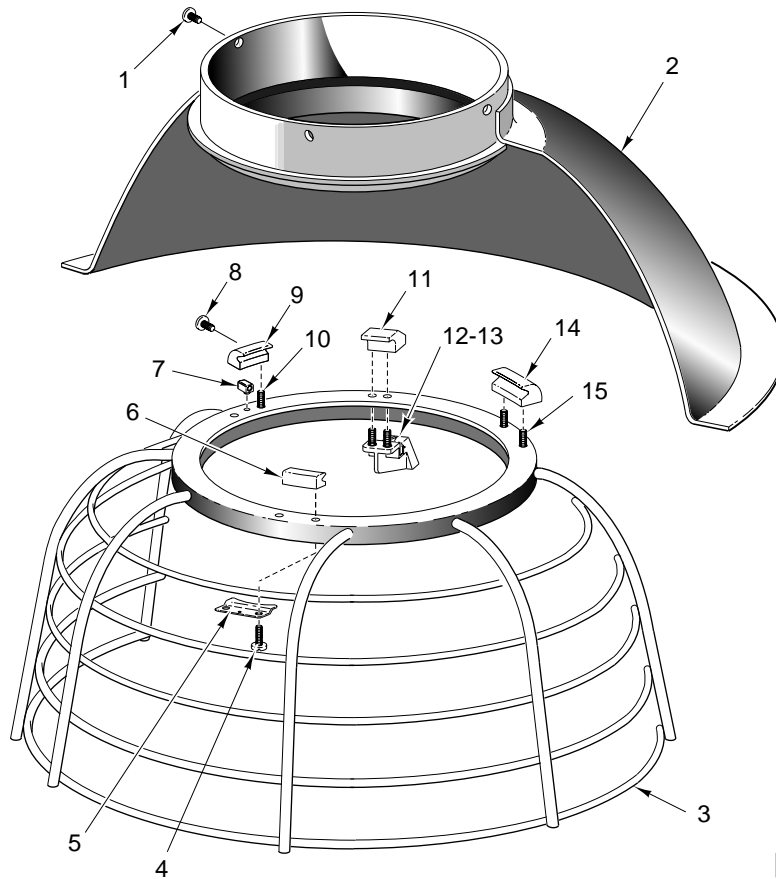

**BOWL GUARD UNIT**

ILLUS. PL-51773	PART NO.	NAME OF PART	AMT.
	1	Mach. Screw 8-32 x 3/8 Truss Hd., Slotted .....	3
	2	Guard & Drip Cup Assy. ....	1
	3	Wire Cage Weldment .....	1
	4	Mach. Screw - "Special" 8-32 x 3/8 Truss Hd. ....	2
	5	Stop - Cage .....	1
	6	Shoe - Front .....	1
	7	Key - Shoe .....	1
	8	Mach. Screw 4-40 x 7/16 Oval HD., "Special" .....	1
	9	Shoe - Adjustable .....	1
	10	Mach. Screw - "Special" 8-32 x 3/8 Truss Hd. ....	2
	11	Bumper - Cage .....	1
	12	Retainer - Magnet .....	1
	13	Mach. Screw 6-32 x 3 3/8 Truss HD., "Special" .....	2
	14	Shoe - Fixed .....	1
	15	Mach. Screw - "Special" 8-32 x 3/8 Truss Hd. ....	2

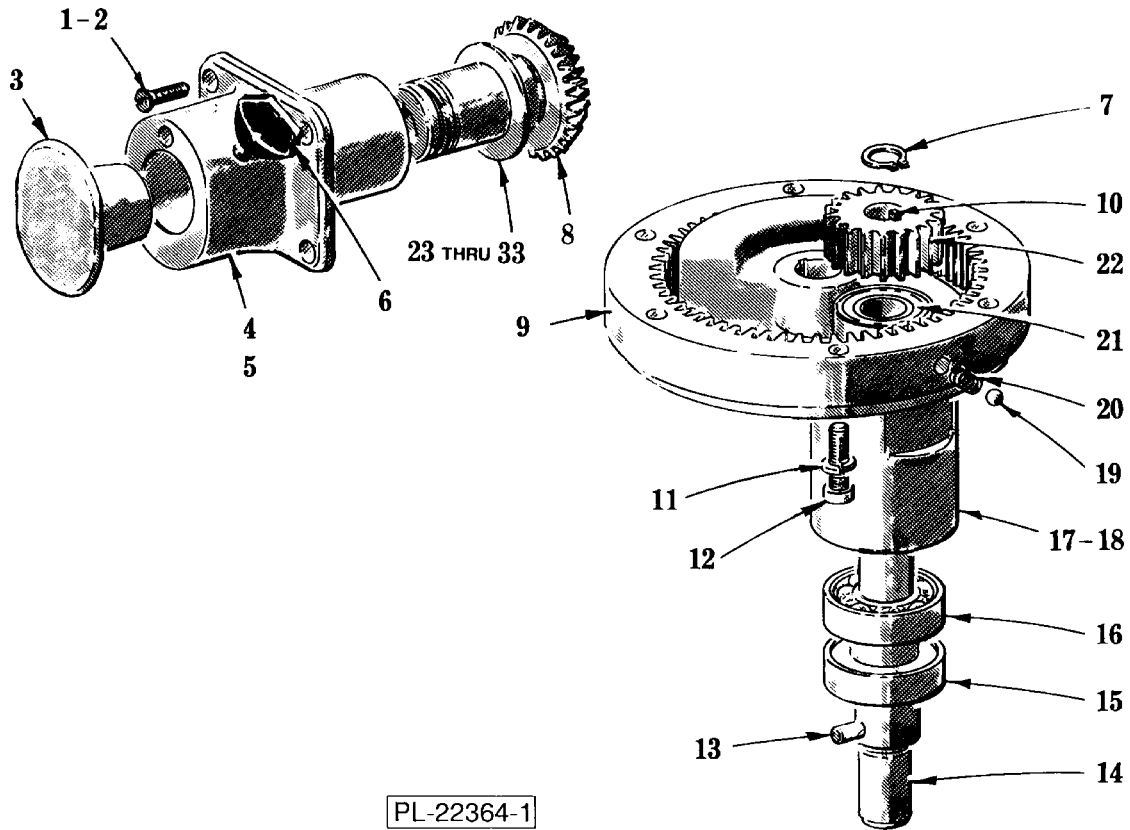

PLANETARY AND ATTACHMENT HUB UNIT

## PLANETARY AND ATTACHMENT HUB UNIT

ILLUS. PL-22364-1	PART NO.	NAME OF PART	AMT.
1	SC-13-71	Mach. Screw 12-24 x 3/4 Flat Hd. (Painted) .....	4
2	SC-14-54	Mach. Screw 12-24 x 3/4 Flat Hd. (Deluxe) .....	4
3	114832-1	Plug - Attachment Hub .....	1
4	435047-4	Hub - Attachment (Painted) .....	1
5	435047-7	Hub - Attachment (Deluxe) .....	1
6	108197-1	Thumb Screw .....	1
7	RR-4-18	Retaining Ring .....	1
8	435065	Bevel Drive Gear & Seal Assy. ....	1
9	438524-2	Internal Gear (63T) (Incls. items 19 & 20) .....	1
10	12430-55	Key 3/16 x 3/16 x 1 .....	1
11	WL-3-35	Lockwasher 1/4 Helical .....	6
12	SC-40-9	Cap Screw 1/4 - 20 x 1 1/4 Fil. Hd .....	6
13	65062-1	Pin .....	1
14	113936	Agitator Shaft Assy. (Incls. item 13) .....	1
15	23482	Seal - Oil (1" I.D.) .....	1
16	BB-20-6	Ball Bearing - N.D. #7504 .....	1
17	23166-1	Planetary (Painted) .....	1
18	23166-6	Planetary (Deluxe) .....	1
19	BA-2-9	Ball 1/4 Dia. ....	2
20	7094	Spring .....	2
21	BB-17-12	Ball Bearing - N.D. #7503 .....	1
22	15217	Pinion - Beater (19T) .....	1
23	12746-19	Washer - Thrust (.115) .....	AR
24	12746-5	Washer - Thrust (.080) .....	AR
25	12746-6	Washer - Thrust (.106) .....	AR
26	12746-7	Washer - Thrust (.092) .....	AR
27	12746-8	Washer - Thrust (.086) .....	AR
28	12746-9	Washer - Thrust (.098) .....	AR
29	12746-10	Washer - Thrust (.112) .....	AR
30	12746-12	Washer - Thrust (.119) .....	AR
31	12746-13	Washer - Thrust (.121) .....	AR
32	12746-16	Washer - Thrust (.129) .....	AR
33	12746-18	Washer - Thrust (.117) .....	AR
	102778-1	Planetary Assy. (Painted) (Incls. items 7, 10, 14 thru 17, 21 & 22) .....	1
	102778-3	Planetary Assy. (Deluxe)(Incls. items 7, 10, 14, 15, 16, 18, 21 & 22) .....	1

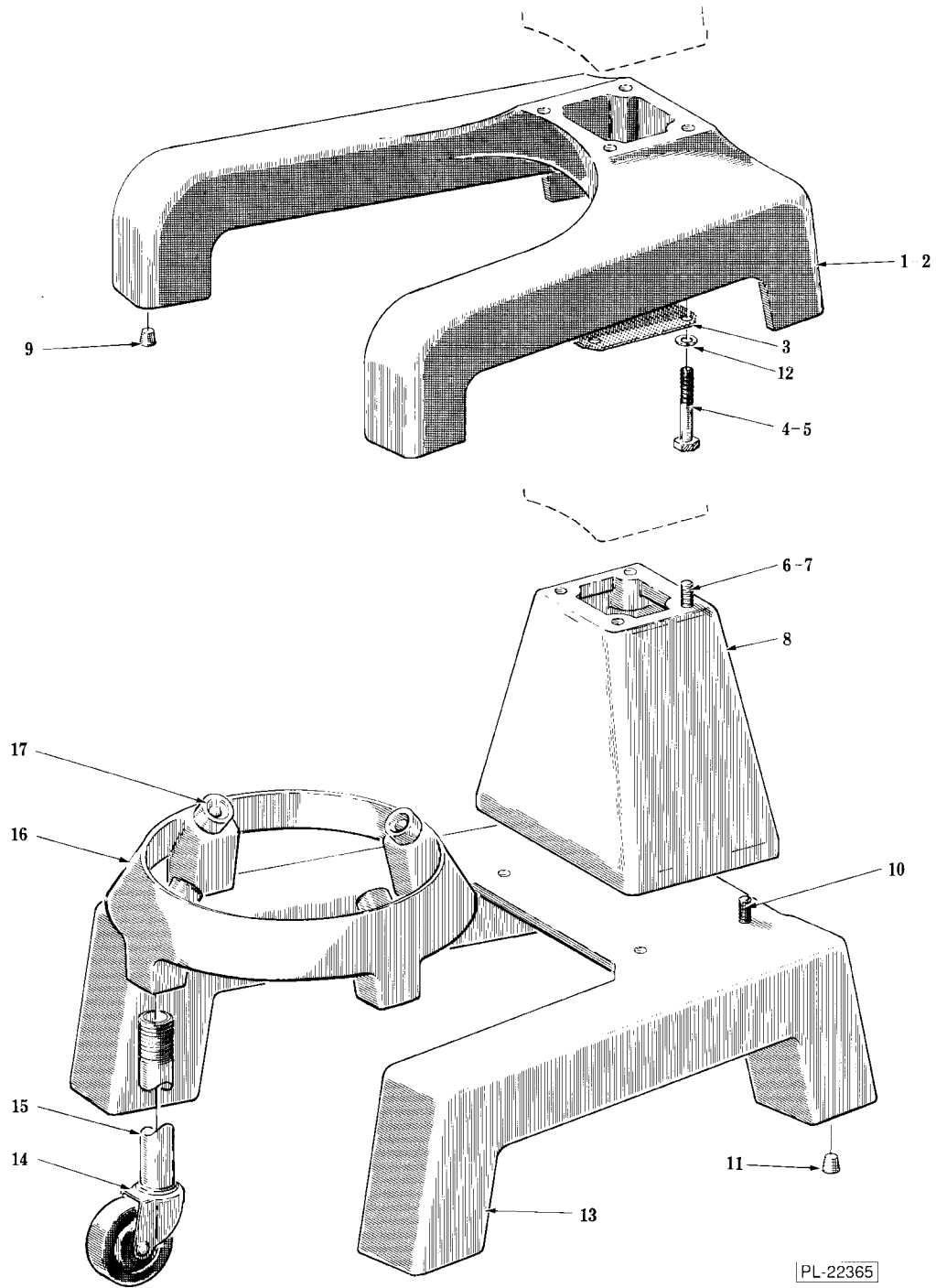

**BASE UNIT**

---

**BASE UNIT**

ILLUS. PL-22365	PART NO.	NAME OF PART	AMT.
1	271915-3	Base (Painted) (Bench Model) .....	1
2	271915-6	Base (Deluxe)(Bench Model) .....	1
3	108159	Screen - Air .....	1
4	SC-97-53	Cap Screw $\frac{3}{8}$ -16 x 2 $\frac{1}{4}$ Hex Hd .....	4
5	SC-62-42	Cap Screw $\frac{3}{8}$ -16 x 1 Hex Hd .....	4
6	SC-62-27	Cap Screw $\frac{3}{8}$ -16 x 1 $\frac{3}{4}$ Hex Hd. ....	4
7	WS-18-19	Washer .....	4
8	74998-4	Block - Riser (Painted) .....	1
9	110717-1	Plug - Base (Plug for Foot Pads) (packed 8) .....	1
10	SC-62-22	Cap Screw $\frac{3}{8}$ -16 x 1 $\frac{1}{4}$ Hex Hd. ....	4
11	110717-1	Plug - Base (Plug for Foot Pads) (packed 8) .....	1
12	WS-18-19	Washer .....	4
13	291499-3	Base (Painted)(Floor Model) .....	1
14	87668-2	Caster .....	4
15	70590-2	Leg - Bowl Truck .....	4
16	315017	Bowl Truck Assy. (Incls. items 14, 15, & 17) .....	1
17	18682-1	Bumper .....	4

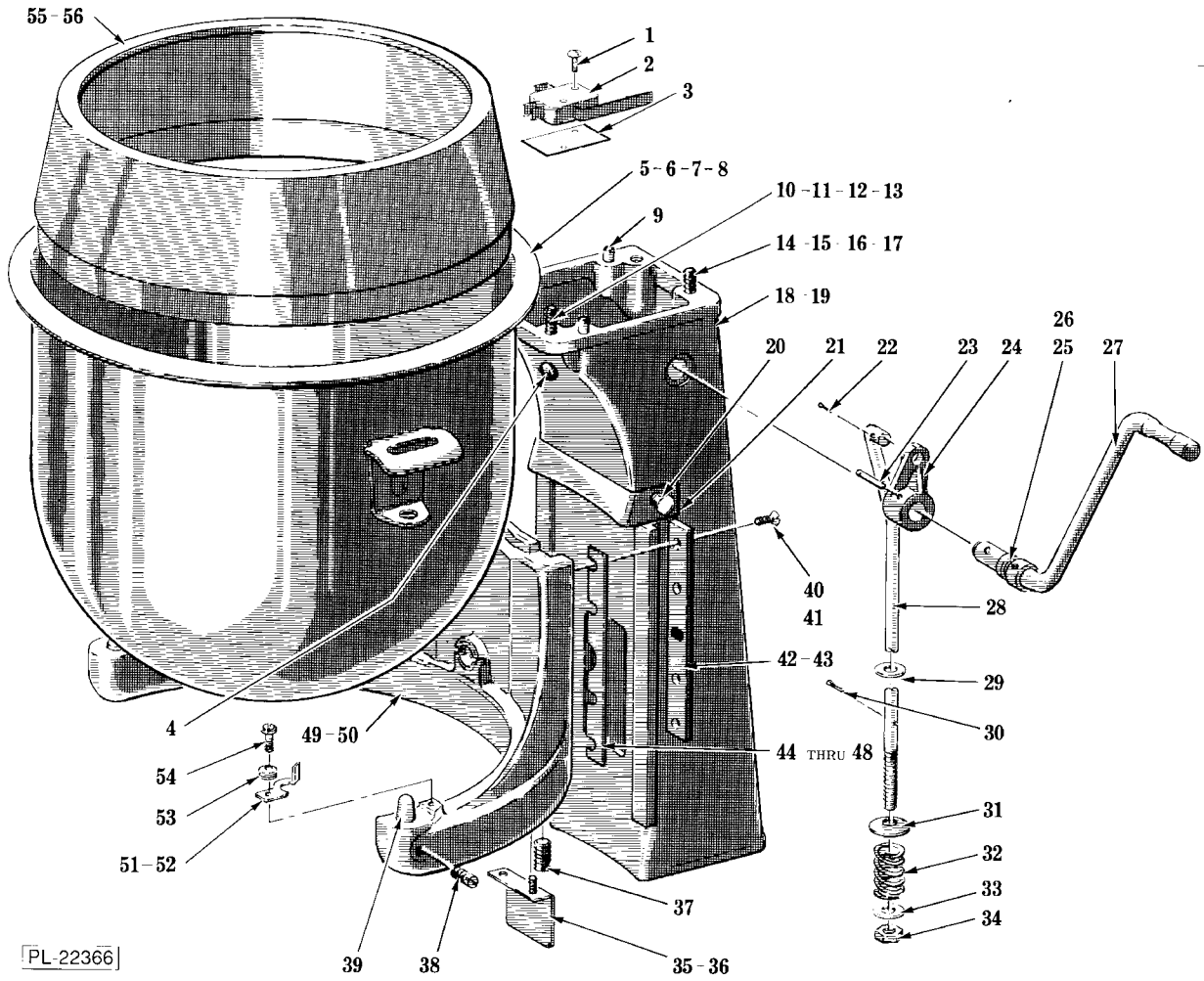

PEDESTAL & BOWL UNIT



## PEDESTAL &amp; BOWL UNIT

ILLUS. PL-22366	PART NO.	NAME OF PART	AMT.
1	SC-60-40	Mach. Screw 4-40 x 5/8 Rd. Hd. ....	2
2	87711-248	Switch - Bowl Height .....	1
3	439892	Insulator - Switch .....	1
4	87711-252-1	Switch - Reed .....	1
5	295645	Bowl Assy. (20 Qt.) (Tinned) .....	1
6	275683	Bowl Assy. (20 Qt.) (SST) .....	1
7	295642	Bowl Assy. (12 Qt.) (Tinned) .....	1
8	295644	Bowl Assy. (12 Qt.) (SST) .....	1
9	270776	Dowel .....	2
10	WL-3-43	Lock Washer 5/16 Light (Painted) .....	2
11	SC-37-85	Cap Screw 5/16 - 18 x 1 Rd. Hd. (Deluxe) .....	2
12	WL-6-22	Lock Washer 5/16 Light (Deluxe) .....	2
13	SC-36-27	Cap Screw 5/16 - 18 x 1 Rd. Hd. (Painted) .....	2
14	SC-11-95	Mach. Screw 5/16 - 18 x 1 Fil. Hd. (Painted) .....	2
15	WL-3-43	Lock Washer 5/16 Light (Painted) .....	2
16	SC-9-98	Mach. Screw 5/16 - 18 x 1 Rd. Hd. (Deluxe) .....	2
17	WL-6-22	Lock Washer 5/16 Light (Deluxe) .....	2
18	438543-2	Pedestal (Painted) .....	1
19	438543-4	Pedestal (Deluxe) .....	1
20	70641-11	Thumb Screw 8-32 "Special" .....	2
21	78506	Shield - Upper Splash .....	1
22	PC-3-55	Cotter Pin 1/8 x 3/4 .....	1
23	PS-4-15	Spirol Pin 1/4 Dia. x 1 1/8 Lg. ....	1
24	114430	Arm - Bowl Lift .....	1
25	WS-9-11	Washer (STL) .....	AR
26	WS-9-13	Washer (Fiber) .....	AR
27	438528	Lift Handle Assy. ....	1
28	15215	Rod - Bowl Lift .....	1
29	WS-6-33	Washer .....	2
30	PC-3-55	Cotter Pin 1/8 x 3/4 .....	1
31	12745	Washer - Special .....	1
32	12782	Spring .....	1
33	WS-6-26	Washer .....	1
34	NS-36-15	Stop Nut 3/8-24 Hex "Special" .....	1
35	SC-60-56	Mach. Screw 10-32 x 5/16 Rd Hd. ....	2
36	78505	Shield - Lower Splash .....	1
37	121625	Set Screw - Special .....	1
38	5014-1	Stud - Bowl Jacket Hook .....	2
39	6938-2	Pin - Bowl Locating .....	2
40	SC-13-49	Mach. Screw 10-24 x 5/8 Flat Hd. (Painted) .....	6
41	SC-14-55	Mach. Screw 10-24 x 5/8 Flat Hd. (Deluxe) .....	6
42	111213-1	Gib - Bowl Support (Painted) .....	2
43	111213-5	Gib Assy. (Deluxe) .....	2
44	113016-1	Shim - Bowl Support (.003" Thk.) .....	AR
45	113016-4	Shim - Bowl Support (.009" Thk.) .....	AR
46	113016-5	Shim - Bowl Support (.015" Thk.) .....	AR
47	113016-6	Shim - Bowl Support (.005" Thk.) .....	AR
48	113016-7	Shim - Bowl Support (.0075" Thk.) .....	AR
49	438538-1	Bowl Support Assy. (Incls. items 37 & 39) (Painted) .....	1
50	438538-2	Bowl Support Assy. (Incls. items 37 & 39) (Deluxe) .....	1
51	291444-1	Clamp - Bowl (L.H.) .....	1
52	291444-2	Clamp - Bowl (R.H. Shown) .....	1
53	291263	Washer - Belleville .....	6
54	274614	Screw - Pivot .....	2
55	438079	Splash Cover & Bowl Extension (20 Qt.) .....	1
56	438078	Splash Cover & Bowl Extension (12 qt.) .....	1
	111676	Shim (Use Between Pedestal & Transmission Case) .....	AR

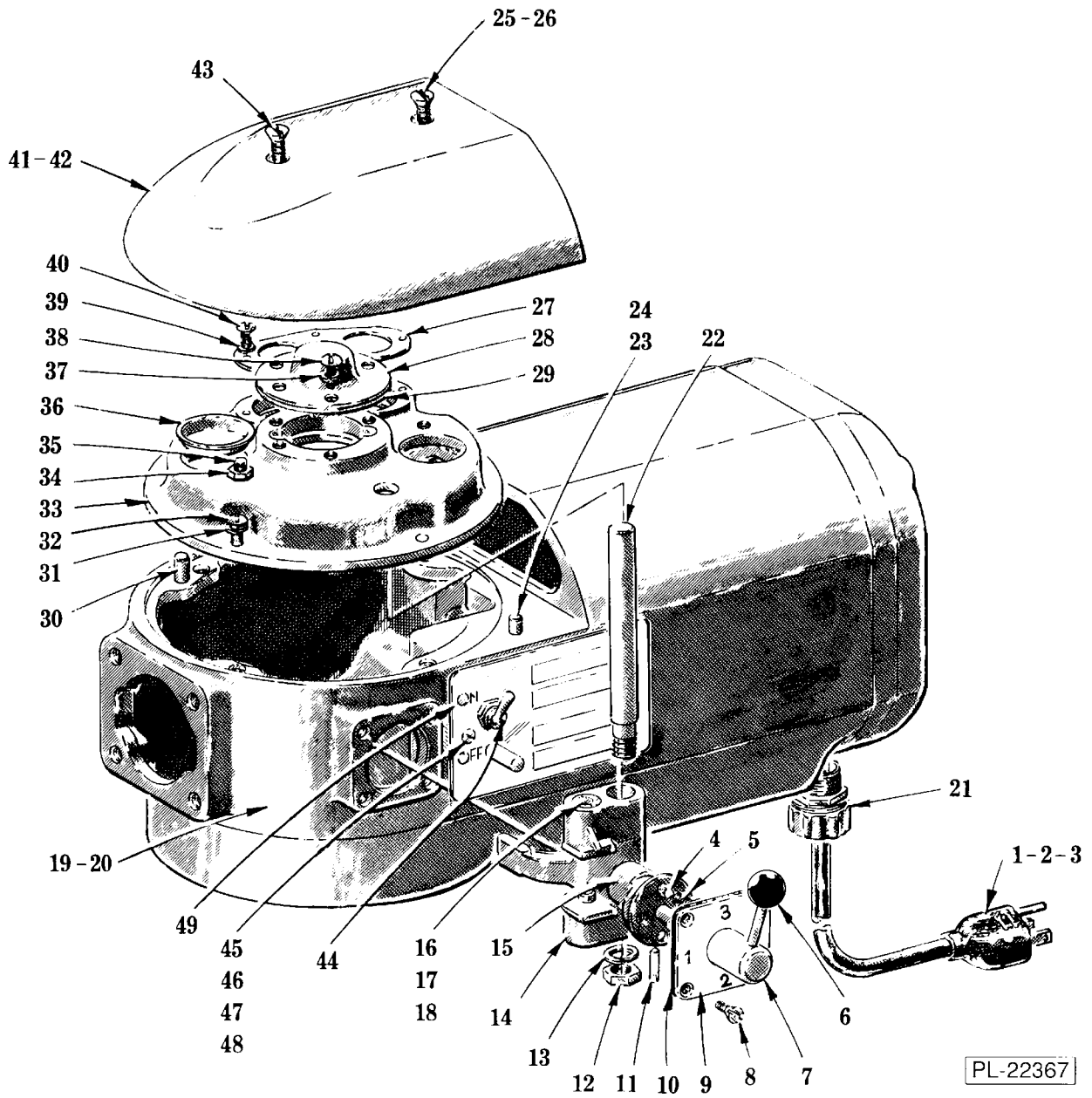

TRANSMISSION CASE AND SHIFTER UNIT

## TRANSMISSION CASE AND SHIFTER UNIT

ILLUS. PL-22367	PART NO.	NAME OF PART	AMT.
1	117542-61	Cord & Plug Assy. (3 Cond., Under 150 V.)	1
2	117542-62	Cord & Plug Assy. (3 Cond., 200-250 V.)	1
3	117542-63	Cord Assy. (I.E.C.)	1
4	BA-2-9	Ball ¼ Dia.	2
5	111170	Spring - Detent	2
6	77401	Knob - Shifter Handle	1
7	437339	Handle - Shifter (Incls. item 6)	1
8	SC-30-24	Mach. Screw 10-24 x ½ Oval Hd)	4
9	290115-1	Plate - Shifter Index	1
10	23946	Gasket - Shifter Index Plate	1
11	PS-3-8	Spirol Pin ½ Dia. x ¾ Lg.	1
12	NS-13-22	Full Nut ¾-16 Hex	1
13	WL-4-2	Lockwasher ¾ Light	1
14	13160	Yoke - Shifter	1
15	114506	Cam - Gear Shifter	1
16	12733	Plunger - Shifter Yoke	2
17	12734	Spring - Shifter Yoke	2
18	12732	Retainer - Shifter Yoke Spring	2
19	438698-1	Case - Transmission (Painted) (Incls. items 23 & 30)	1
20	438698-2	Case - Transmission (Deluxe) (Incls. items 24 & 30)	1
21	FE-22-84	Connector - Strain Relief	1
22	12735	Rod - Shifter Guide	1
23	11800-61	Dowel (Painted)	2
24	11800-62	Dowel (Deluxe)	2
25	SC-15-57	Mach. Screw 12-24 x 1½ Oval Hd. (Deluxe)	1
26	NS-9-36	Mach. Nut 12-24 Hex	2
27	12708	Retainer - Twin Bearing	1
28	20394-1	Cap - Bearing Retainer	1
29	20395	Retainer - Bearing	1
30	11800-116	Dowel	1
31	WL-3-28	Lockwasher 12 Light	4
32	SC-119-7	Mach. Screw 12-24 x ¾ Hex Hd	4
33	67750	Transmission Shaft Support & Screw Assy. (Incls. items 34 & 35)	1
34	NS-9-36	Mach. Nut 12-24 Hex	1
35	SC-8-56	Mach. Screw 12-24 x ½ Rd. Hd	1
36	64871	Plug - Friction	2
37	WL-3-28	Lockwasher 12 Light	3
38	SC-8-48	Mach. Screw 12-24 x ½ Rd. Hd	3
39	WL-3-22	Lockwasher 10 Light	4
40	SC-18-1	Mach. Screw 10-24 x ¾ Pan Hd.	4
41	18231-3	Cover - Transmission Case (Painted)	1
42	439398-3	Cover - Transmission Case (Deluxe)	1
43	SC-16-17	Mach. Screw 12-24 x 1¼ Oval Hd. (Deluxe)	1
44	87711-143-1	Switch - Toggle (NVR)	1
45	123109	Screw 6-32 x ¾ Serrated Hd.	2
46	SC-27-28	Mach. Screw 8-32 x ¼ Rd. Hd. (Grounding Screw)	1
47	WL-11-1	Lock Washer 8 Int. Shakeproof (Ground Screw) (1 Ph)	2
48	NS-10-11	Mach. Nut 8-32 Hex (Ground Screw) (1 Ph)	1
49	438537-2	Switch Plate & Pin Assembly	1
	79999	Shifter Assy. (Incls. items 4, 5, 7, 9, 11, & 15)	1
	88795	Shifter Yoke Assy. (Incls. items 14, 16, 17, & 18)	1

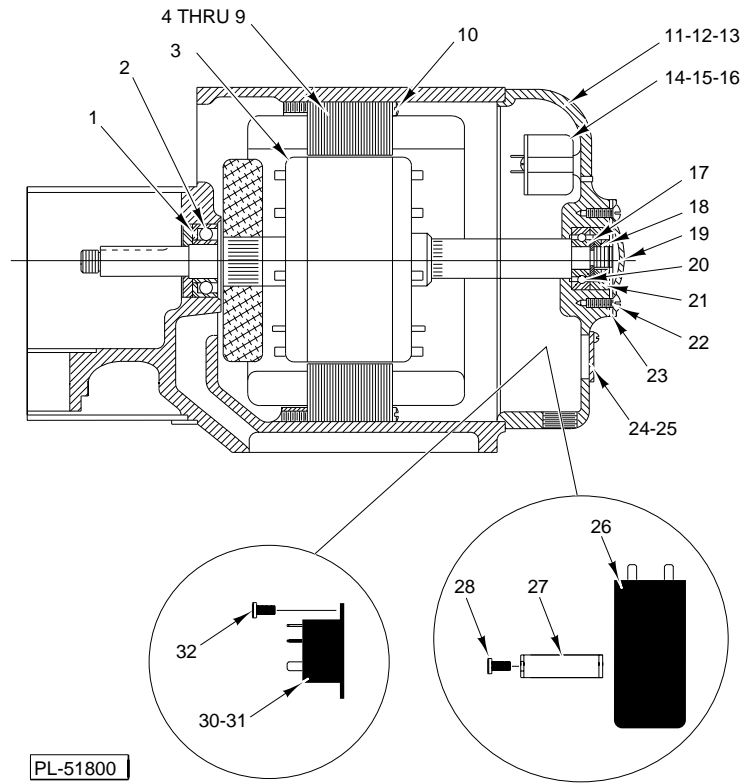

PL-51800

**MOTOR PARTS (A200 SERIES)**

ILLUS.	PART NO.	NAME OF PART	AMT.
PL-51800			
1	13174-1	Deflector - Grease .....	1
2	BB-5-30	Ball Bearing - N.D #C8503 .....	1
3	22275-274	Rotor Assy .....	1
4	65477-164-1	Stator Assy. (115 V., 60 HZ) .....	1
5	65477-164-5	Stator Assy. (230V., 60 HZ) .....	1
6	65477-164-2	Stator Assy. (115V., 50 HZ) .....	1
7	65477-164-6	Stator Assy. (220 V., 50 HZ) .....	1
8	65477-164-3	Stator Assy. (100 V., 60 HZ., 1 PH) .....	1
9	65477-164-4	Stator Assy. (100 V., 50 HZ., 1 PH) .....	1
10	SC-12-59	Mach. Screw 10-24 x 2 1/4 Fil. Hd .....	4
11	438536-2	Bracket - Bearing (Painted) .....	1
12	438536-4	Bracket - Bearing (Deluxe) .....	1
13	SC-16-31	Mach. Screw 12-24 x 2 Oval Hd .....	4
14	271612-2	Switch - Electronic Start (50/60 Hz.) .....	1
15	271794-1	Standoff - Switch .....	2
16	SC-9-64	Mach. Screw 6-32 x 1 Rd. Hd. ....	2
17	WS-7-9	Washer - Special .....	1
18	11430	Nut - Special .....	2
19	294306-1	Cap - Cover (Deluxe) .....	1
20	BB-17-5	Ball Bearing N.D. #7601 .....	1
21	12669	Spacer - Bearing .....	1
22	SC-10-32	Mach. Screw 8-32 x 3/8 Truss Hd. ....	4
23	24464	Gasket - Cover Cap .....	1
24	115231-2	Cover - Conduit .....	1
25	123109	Screw 6-32 x 3/8 Serrated Hd. ....	2
26	70487-18	Capacitor .....	1
27	271937	Clip - Capacitor Retaining .....	1
28	SC-18-77	Mach. Screw 6-32 x 5/16 Phil Pan Hd. (Use with Capacitor Clip) .....	1
29	WL-3-9	Lockwasher 6 Medium .....	1
30	87714-42-1	Relay (2 Pole)(Under 150 V.) .....	1
31	87714-42-3	Relay (2 Pole) (220 - 240 V.) .....	1
32	SC-18-77	Mach. Screw 6-32 x 5/16 Phil Pan Hd. ....	2
	SC-27-15	Mach. Screw 6-32 x 1/4 Rd. Hd. (Ground) .....	1
	WL-11-20	Lockwasher 6 Int. (Use With Grounding Screw) .....	1

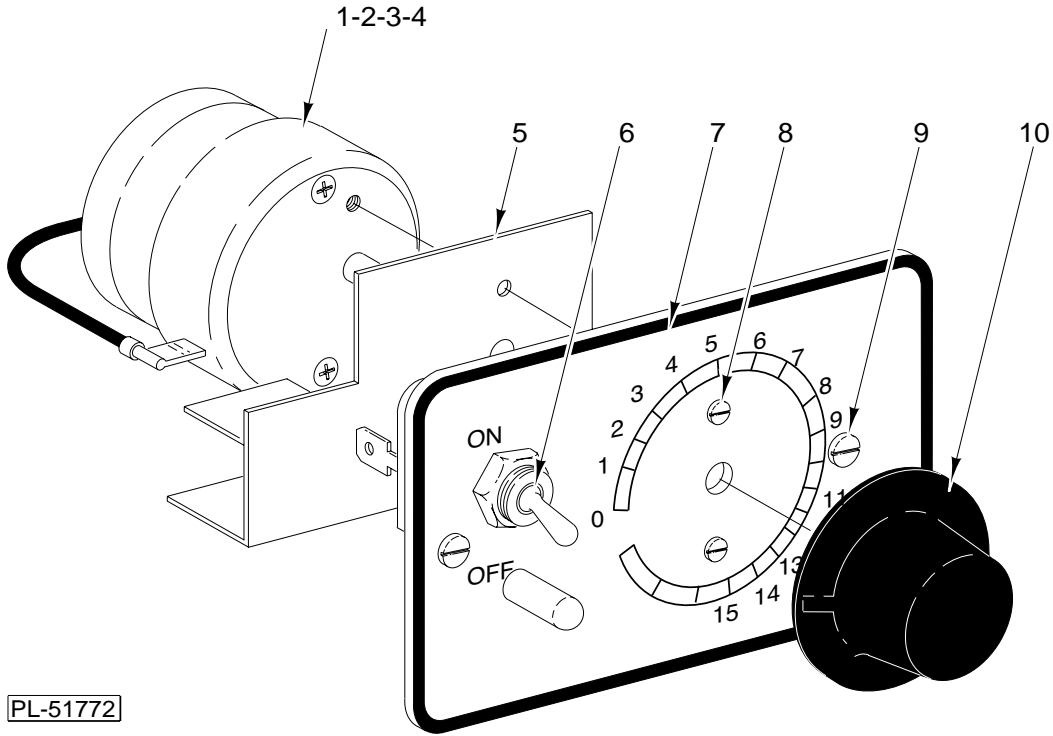

**SWITCH & TIMER UNIT**

ILLUS. PL-51772	PART NO.	NAME OF PART	AMT.
1	294650-4-5	Timer (115 V., 60 Hz.) .....	1
2	294650-4-6	Timer (230 V., 60 Hz.) .....	1
3	294650-4-7	Timer (115 V., 50 Hz.) .....	1
4	294650-4-8	Timer (220 V., 50 Hz.) .....	1
5	291746	Insulator - Switch .....	1
6	120388	Switch & Label Assy. ....	1
7	438537-1	Switch Plate & Pin Assy. ....	1
8	SC-13-7	Mach. Screw 5-40 x 1/4 Flat Hd. ....	2
9	123109	Screw 6-32 x 3/8 Serrated Hd. ....	2
10	291748	Knob - Timer .....	1

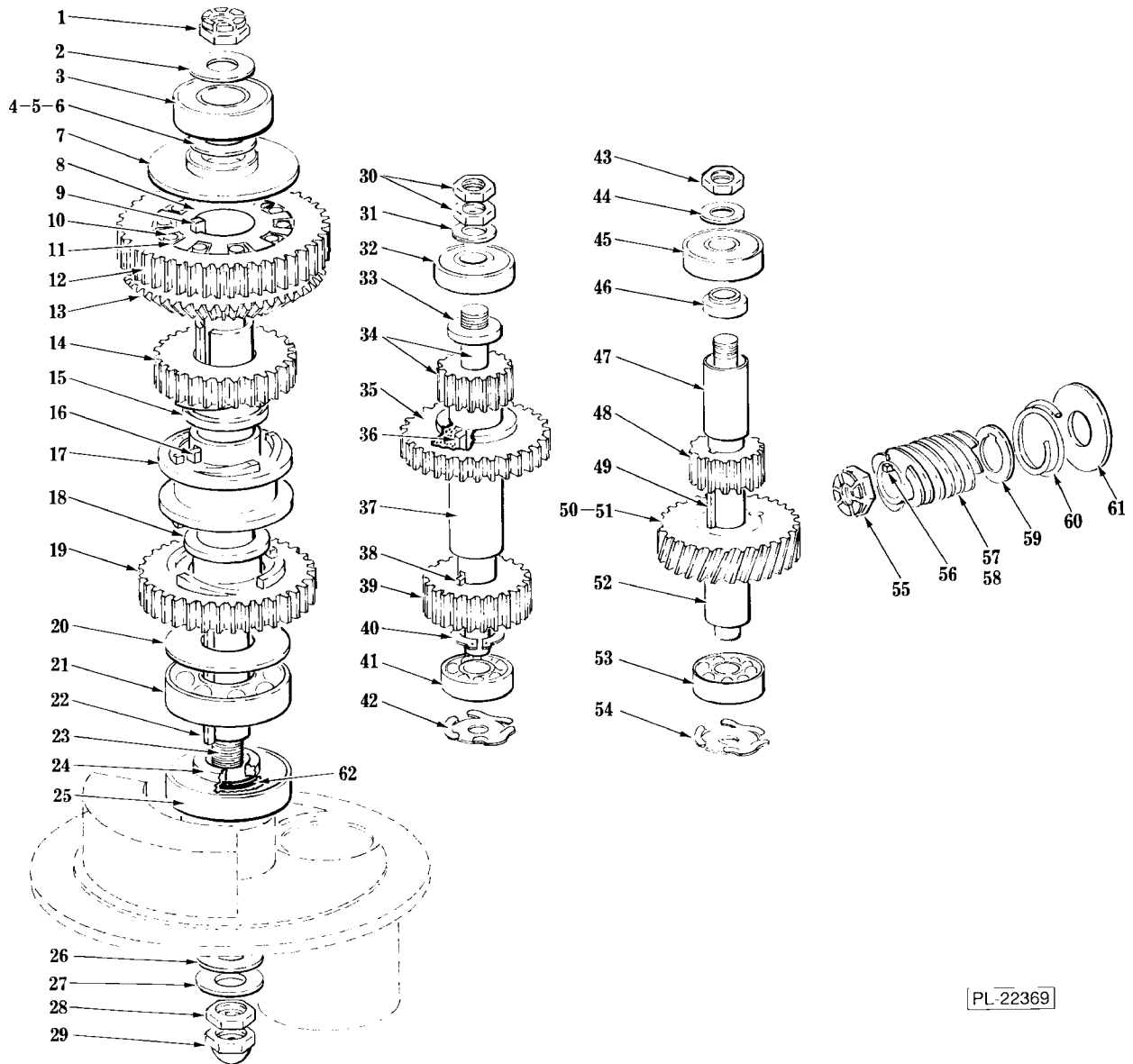

**TRANSMISSION GEAR UNIT**

PL-22369

## TRANSMISSION GEAR UNIT

ILLUS. PL-22369	PART NO.	NAME OF PART	AMT.
1	NS-32-29	Stop Nut ½-20 "Flexloc" .....	1
2	WS-8-13	Washer - Retaining .....	1
3	BB-20-18	Ball Bearing - N.D. #77503 .....	1
4	WS-10-18	Washer - Bearing Shim (.002" Thk.) .....	AR
5	WS-10-19	Washer - Bearing Shim (.003" Thk.) .....	AR
6	WS-10-20	Washer - Bearing Shim (.010" Thk.) .....	AR
7	107145	Spacer - Planetary Shaft .....	1
8	124730	Sleeve - Roller Clutch Drive .....	1
9	109070-2	Key .....	1
10	124729	Clutch - Roller .....	10
11	124732	Spring - Roller .....	10
12	124752	Gear - Slow Speed (46T) .....	1
13	124733	Gear - Bevel (46T) .....	1
14	124744	Gear - Clutch (29T) .....	1
15	12695	Bearing - Clutch Gear .....	1
16	12430-59	Key - Clutch Sleeve .....	2
17	70035-1	Sleeve - Clutch .....	1
18	12695	Bearing - Clutch Gear .....	1
19	124743	Gear - Lower Clutch (38T) .....	1
20	12723	Spacer - Lower .....	1
21	BB-20-6	Ball Bearing - N.D. #7504 .....	1
22	12430-17	Key .....	1
23	124734	Shaft - Planetary .....	1
24	437342	Spacer - Bearing .....	1
25	114695	Seal - Oil .....	1
26	124946	Washer - Fiber .....	1
27	WS-24-1	Washer - Retaining (STL) .....	1
28	10928-2	Nut - Special .....	1
29	24715-3	Acorn Nut ½ - 20 .....	1
30	12710	Nut - Retaining .....	2
31	WS-6-36	Washer - Retaining .....	1
32	BB-5-2	Ball Bearing - N.D. #7500 .....	1
33	12744	Spacer - Upper .....	1
34	291236	Shaft - Transmission (15T) .....	1
35	124736	Gear (32T) .....	1
36	435297	Key .....	1
37	12697	Spacer - Lower .....	1
38	435297	Key .....	1
39	124760	Gear (23T) .....	1
40	RR-4-18	Retaining Ring .....	1
41	BB-5-1	Ball Bearing - N.D. #3200 .....	1
42	SL-2-8	Spring - Preloading - N.D. #S-10-B .....	1
43	12710	Nut - Retaining .....	1
44	WS-6-36	Washer - Retaining .....	1
45	BB-5-2	Ball Bearing - N.D. #7500 .....	1
46	124745	Washer .....	1
47	124765-1	Spacer - Gear .....	1
48	124748	Gear (15T) .....	1
49	12430-4	Key .....	1
50	124751-3	Worm Wheel & Bushing Assy. (60 Hz.) .....	1
51	124749-2	Worm Wheel & Bushing Assy. (50 Hz.) .....	1
52	291128	Shaft - Worm Wheel .....	1
53	BB-5-1	Ball Bearing - N.D. #3200 .....	1
54	SL-2-8	Spring - Preloading - N.D. #S-10-B .....	1
55	NS-32-23	Lock Nut ¾-20 "Flexloc" .....	1
56	12747	Key .....	1
57	291221	Worm (5T)(60 Hz.) .....	1
58	70407	Worm (5T)(50 Hz.) .....	1
59	12754	Washer .....	1
60	12757	Spring - Shock Absorber .....	1
61	12711	Washer - Shock Absorber Spring .....	1
62	67500-78	"O" Ring .....	1
	292799	Planetary Shaft Assy.(Incls. items 7, 8, 9, 12 thru 20 & 23) .....	1
	292800	Transmission Shaft Assy. (Incls. items 33 thru 40) .....	1
	292798-1	Worm Wheel Shaft Assy. (60Hz.)(Incls. items 46 thru 50 & 52) .....	1
	292798-2	Worm Wheel Shaft Assy. (50 Hz.)(Incls. items 46 thru 49, 51 & 52) .....	1

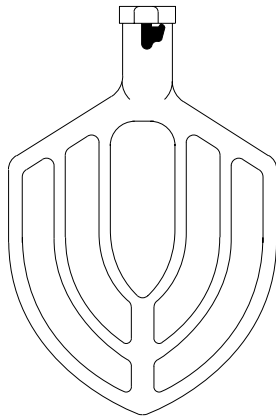

1-2

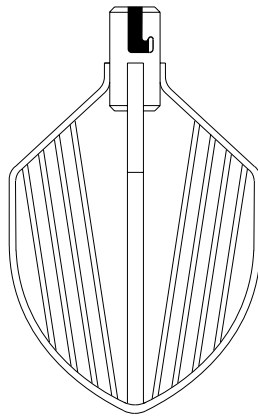

3

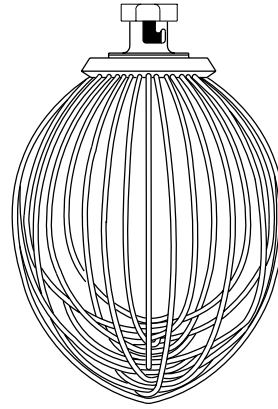

4

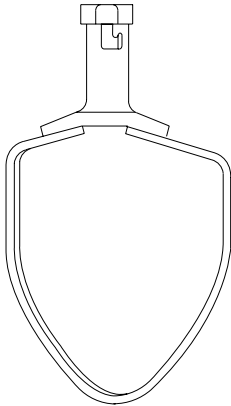

8

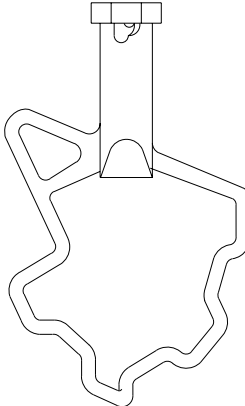

7

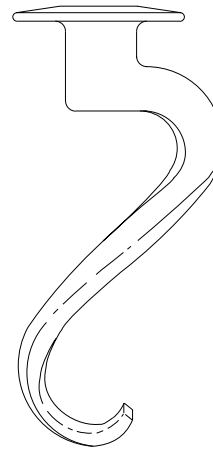

5-6

PL-51801

**AGITATORS**

ILLUS. PL-51801	PART NO.	PART NO.	NAME OF PART	AMT.
1	275459	295032	"B" Flat Beater .....	1
2	275559	295040	"B" Flat Beater (SST) .....	1
3	295165	-----	"C" Wing Whip .....	1
4	275897	295027	"D" Wire Whip (SST) .....	1
5	275931	-----	"ED" Dough Arm .....	1
6	295119	275978	"E" Dough Arm .....	1
7	295020	-----	"S" Sweet Dough Beater .....	1
8	295036	-----	"P" Pastry Knife .....	1