



零 部 件 手 册
Parts manual

C系列44BP型号洗碗机
MODEL C44BP SERIES
DISHWASHERS

模式 右至左操作 左至右操作
(R-L) (L-R)

MODE: LEFT TO RIGHT OPERATION
RIGHT TO LEFT OPERATION

高达食品设备有限公司
HOBART FOOD EQUIPMENT CO., LTD.

Start series from: 2115060001
DSN: CC-11-02 V1.6 1506

目录

序号	描述	页码
1	层架及导轨(清洗部分)	3
2	洗臂及管路	5
3	水位保护	7
4	触碰开关机构	9
5	排水部分	11
6	门、门帘、隔板及滤网	13
7	其他零件(清洗部分)	15
8	电加热及水位控制	17
9	输送传动部件	19
10	控制盒及加热器外罩	21
11	控制盒面板组件	23
12	传动马达	25
13	清洗水泵	27
14	加热器总成	31
15	喷淋管路总成 R-L	33
16	喷淋管路总成 L-R	35
17	喷淋管路总成(不带升温箱)	37
18	进水管组件(带升温箱)	39
19	进水管组件(不带升温箱)	43

CONTENT

NO.	Description	Page
1	TRACK AND CRADLE	3
2	WASH ARMS AND TUBES	5
3	WATER PROTECTION	7
4	ACTUATOR MECHANISM	9
5	DRAIN UNIT	11
6	DOOR, CURTAINS, BAFFLES, AND STRAINERS	13
7	MISCELLANEOUS	15
8	ECLECTRIC HEAT	17
9	CONVEYOR DRIVE TRAIN	19
10	CONTROL BOX AND BOOSTER COVER	21
11	COMPONENT PANEL	23
12	CONVEYOR DRIVE MOTOR	25
13	WASH MOTOR AND PUMP UNIT	27
14	BOOSTER ASSY	31
15	RINSE SYSTEM R-L	33
16	RINSE SYSTEM L-R	35
17	RINSE SYSTEM WITHOUT BOOSTER	37
18	FILLING SYSTEM (WITH BOOSTER)	39
19	FILLING SYSTEM (WITHOUT BOOSTER)	43

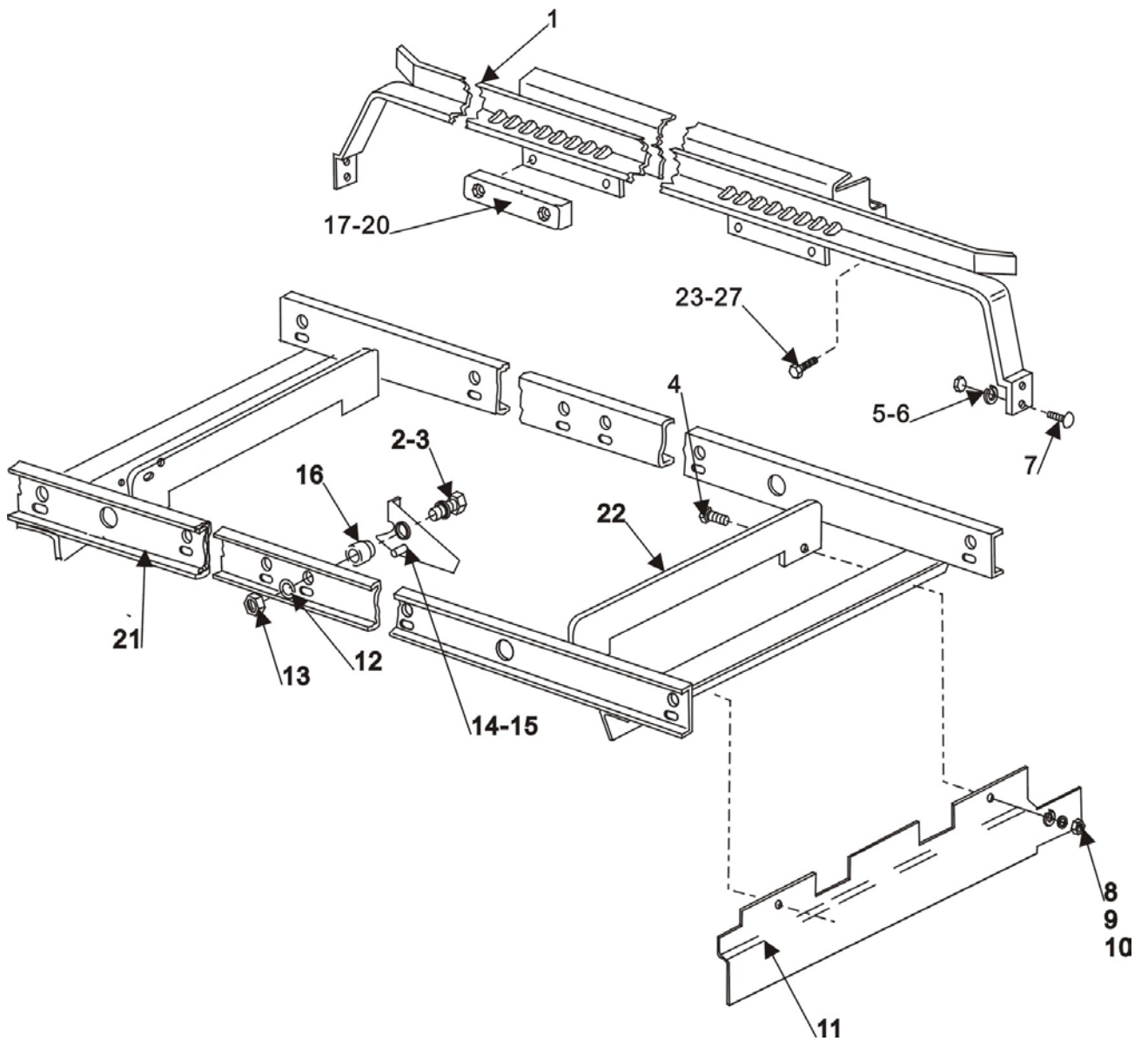

Fig.1 层架及导轨(清洗部分)
TRACK AND CRADLE

C44BP SERIES DISHWASHER REPLACEMENT PARTS

层架及导轨(清洗部分)
TRACK AND CRADLE

序号 No.	物料号 Part No	名称	Description	数量 Qty
1	742306	碗架焊件	Rack Track	2
2	WS-018-04	垫圈	Washer	6
3	SC-041-31	螺钉 3/8-16 x 1 1/4 Hex Hd	Cap Screw 3/8-16 x 1 1/4 Hex Hd	6
4	SC-041-10	螺钉5/16-18 x 5/8 Hex Hd	Cap Screw 5/16-18 x 5/8 Hex Hd	4
5	NS-015-11	螺母 5/16 – 18 Hex	Nut 5/16 – 18 Hex	8
6	WL-006-23	防松垫圈	Lockwasher 5/16 Medium (SST)	8
7	SC-041-11	螺钉5/16-18 x 3/4 hex Hd. (SST)	Cap Screw 5/16-18 x 3/4 hex Hd. (SST)	8
8	NS-015-11	螺母 5/16 – 18 Hex	Nut 5/16 – 18 Hex	4
9	WS-017-08	防松垫圈	Washer	4
10	WL-006-23	垫圈	Lockwasher 5/16 Medium (SST)	4
11	742214	导轨右下挡板(R-L)	Baffle – Lower (R – L Only)	1
12	WL-006-28	防松垫圈	Lockwasher 3/8 Medium	6
13	NS-015-13	螺母3/8-16 Hex	Nut 3/8-16 Hex	6
14	436704-1	拨叉(右边)	Dog (Front, R-L) (Rear, L-R)	3
15	436704-2	拨叉(左边)	Dog – Not Shown (Front, L-R)(Rear, R-L)	3
16	270983	小套筒	Spacer	6
17	473231	滑块 USE 00-941181	Slider – Large	4
18	SC-041-15	螺钉5/16 – 18 x 1 1/4 Hex Hd	Cap Screw 5/16 – 18 x 1 1/4 Hex Hd	8
19	WL-006-23	防松垫圈	Lockwasher 5/16 Medium (SST)	8
20	NS-015-11	螺母5/16 – 18 Hex	Nut 5/16 – 18 Hex	8
21	742329	导轨焊件	Cradle	1
22	742130	导轨左右上挡板	Baffle – Cradle Upper	2
23	SC-041-31	螺钉3/8-16 x 1 1/4 Hex Hd	Cap Screw 3/8-16 x 1 1/4 Hex Hd	2
24	SC-041-11	螺钉5/16-18 x3/4 Hex Hd.(SST)	Cap Screw 5/16-18 x3/4 Hex Hd. (SST)	10
25	WS-017-01	垫圈	Washer	20
26	WL-006-23	防松垫圈	Lockwasher 5/16 Medium (SST)	14
27	NS-015-11	螺母5/16 – 18 Hex	Nut 5/16 – 18 Hex	14

C44BP SERIES DISHWASHER REPLACEMENT PARTS

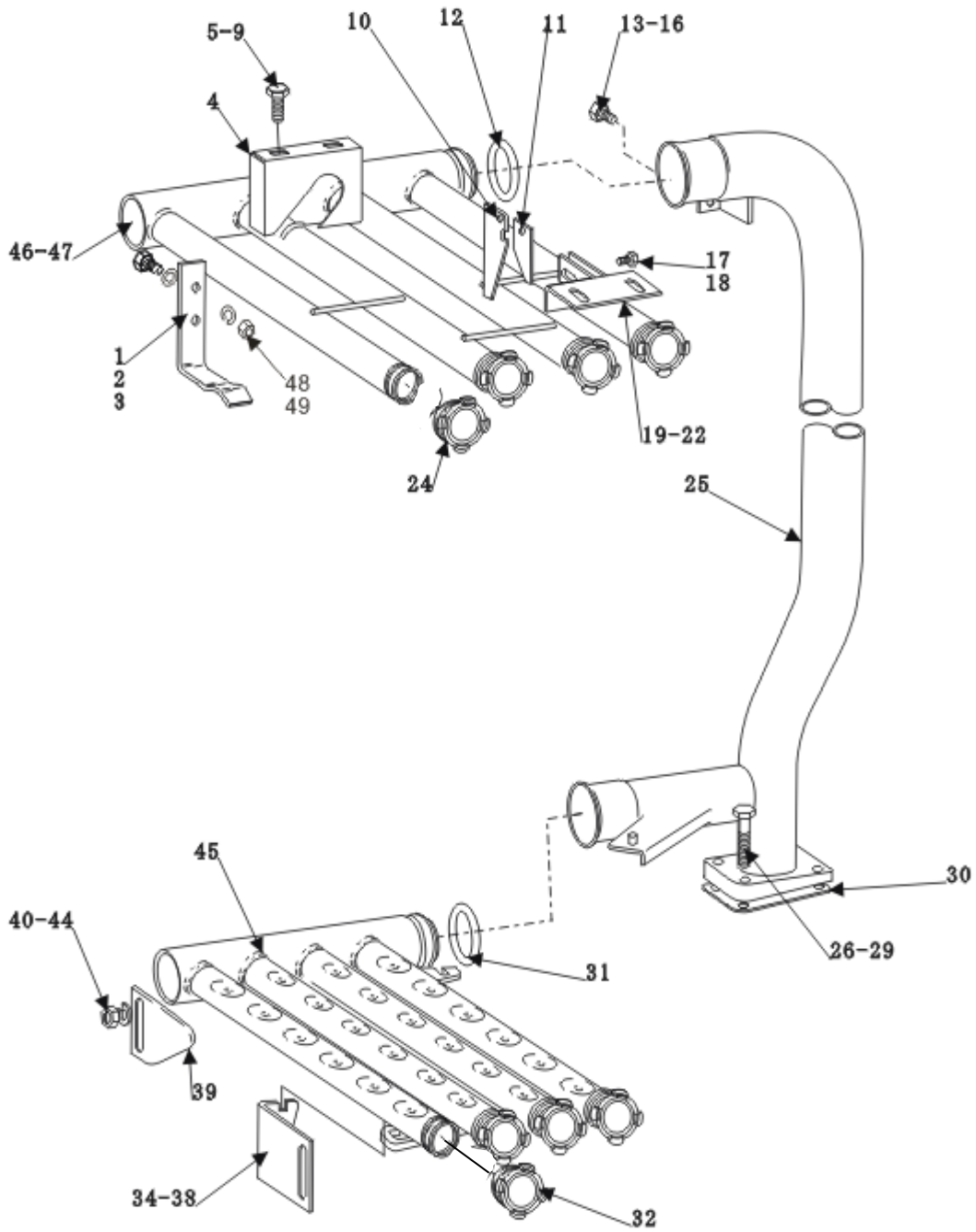

Fig.2 洗臂及管路
WASH ARMS AND TUBES

C44BP SERIES DISHWASHER REPLACEMENT PARTS

洗臂及管路
WASH ARMS AND TUBES

序号 No.	物料号 Part No	名称	Description	数量 Qty
1	436947-1	支撑悬臂(洗室后上部)	Hanger	2
2	SC-041-05	螺钉 1.4-20 x 1/2 Hex Hd	Cap Screw 1.4-20 x 1/2 Hex Hd	4
3	WL-006-17	防松垫圈	Lockwasher1/4	4
4	742187	上清洗臂支撑座(后)	Guide – Upper Wash Arm	1
5	SC-041-11	螺钉5/16-18 x3/4 Hex Hd.(SST)	Cap Screw 5/16-18 x3/4 Hex Hd.(SST)	2
6	WS-017-01	垫圈	Washer.	2
7	WS-017-08	垫圈	Washer	2
8	WL-006-23	防松垫圈	Lockwasher 5/16 Medium (SST)	2
9	NS-015-11	螺母5/16-18 Hex	Nut 5/16-18 Hex	2
10	289760	上洗臂前挂钩(大)	Latch	1
11	289759	上洗臂前挂钩(小)	Latch	1
12	67500-110	O型圈	O Ring	1
13	SC-041-01	螺钉1/4 –20 x 3/4 Hex Hd	Cap Screw 1/4 –20 x 3/4 Hex Hd	1
14	WS-022-01	垫圈	Washer	2
15	WL-006-17	防松垫圈	Lockwasher1/4	1
16	NS-015-01	螺母1/4-20 Hex (SST)	Nut 1/4-20 Hex (SST)	1
17	SC-041-01	螺钉1/4 –20 x 3/4 Hex Hd	Cap Screw 1/4 –20 x 3/4 Hex Hd	2
18	NS-031-19	螺母1/4-20 Elastic (SST)	Stop Nut 1/4-20 Elastic (SST)	2
19	742308	洗臂支撑座焊件(前)	Bracket	1
20	WS-017-08	垫圈	Washer	2
21	WL-006-23	防松垫圈	Lockwasher 5/16 Medium (SST)	2
22	NS-015-11	螺母5/16-18 Hex	Nut 5/16-18 Hex	2
24	ML102845	胶堵-清洗臂	Plug – Wash Arm	4
	67500-127	O型圈	O Ring	4
	475087	洗臂堵	Plug – Wash Arm	4
25	742307	内部清洗管焊件	Wash Pipe	1
26	SC-041-18	螺钉5/16 –18 x 1 3/4 Hex Hd (SST)	Cap Screw 5/16 –18 x 1 3/4 Hex Hd (SST)	4
27	WS-017-08	垫圈	Washer	8
28	WL-006-23	防松垫圈	Lockwasher 5/16 Medium (SST)	4
29	NS-015-11	螺母5/16-18 Hex	Nut 5/16-18 Hex	4
30	270968	胶垫(喷淋进水管用)	Gasket- Wash Pipe	1
31	67500-110	O型圈	O Ring	1
32	ML102845	胶堵-清洗臂	Plug – Wash Arm	4
	67500-127	O型圈	O Ring	4
	475087	洗臂堵	Plug – Wash Arm	4
34	742185	下清洗臂支架(前)	Catch-Adjustable	1
35	NS-015-11	螺母5/16-18 Hex	Nut 5/16-18 Hex	2
36	WL-006-23	防松垫圈	Lockwasher 5/16 Medium (SST)	2
37	WS-017-08	垫圈	Washer	2
38	SC-041-11	螺钉 5/16-18 x3/4 Hex Hd. (SST)	Cap Screw 5/16-18 x3/4 Hex Hd. (SST)	2
39	742184	下清洗臂支架(后)	Support – Adjustable	1
40	SC-041-13	螺钉5/16-18 x1Hex Hd. (SST)	Cap Screw 5/16-18 x1Hex Hd. (SST)	2
41	SC-041-11	螺钉 5/16-18 x3/4 Hex Hd. (SST)	Cap Screw 5/16-18 x3/4 Hex Hd. (SST)	2
42	WL-006-23	防松垫圈	Lockwasher 5/16 Medium (SST)	2
43	WS-017-08	垫圈	Washer	2
44	NS-015-11	螺母5/16-18 Hex	Nut 5/16-18 Hex	2
45	742305	下清洗臂	Wash Arm- Lower	1
46	742330	上清洗臂(R-L)	Wash Arm (R-L)	1
47	742331	上清洗臂(L-R)	Wash Arm (L-R)	1
48	WS-022-01	弹垫	Lock washer	4
49	NS-031-21	止退母	Nut	4

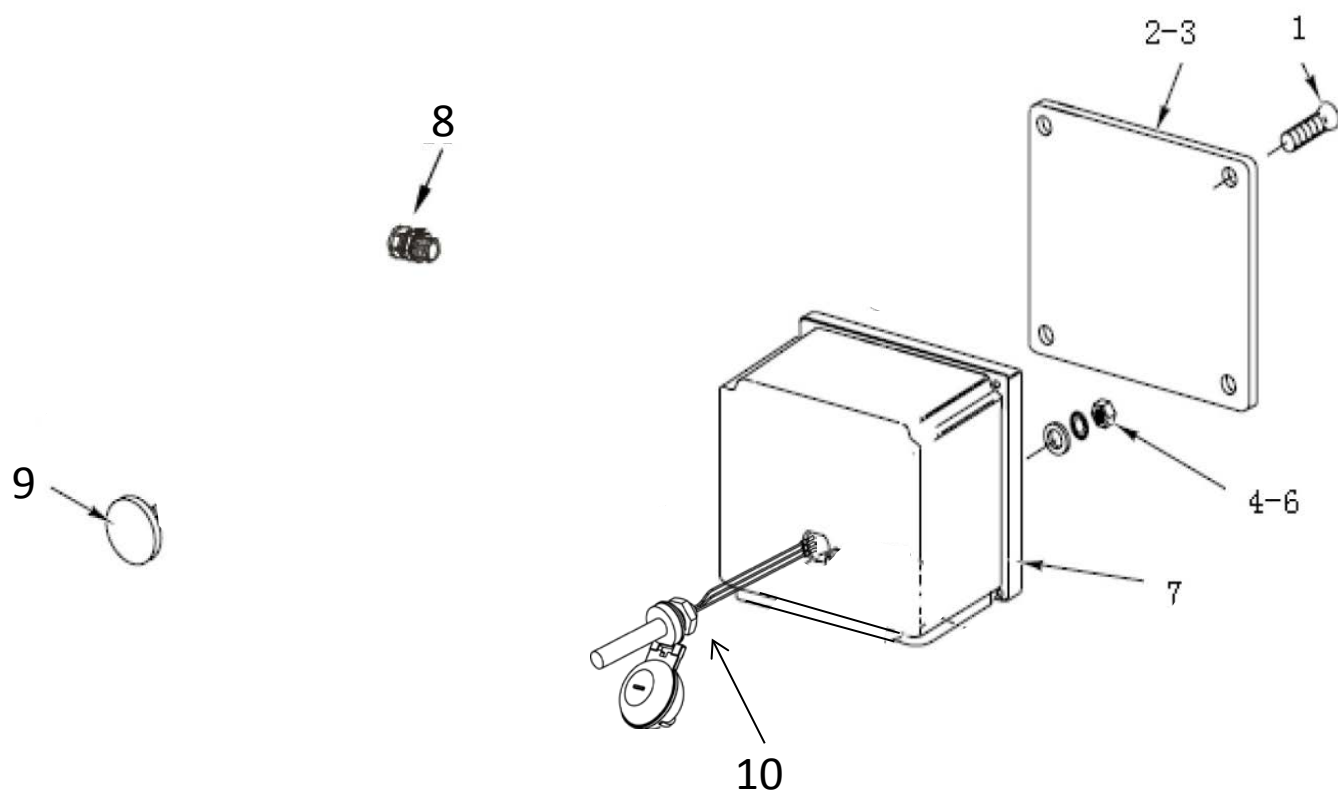

Fig.3 水位保护
WATER PROTECTION

C44BP SERIES DISHWASHER REPLACEMENT PARTS

水位保护 WATER PROTECTION

序号 No.	物料号 Part No	名称	Description	数量 Qty
1	SD-012-20	螺钉8-32 x1/2	Self – Tapping Screw 8-32 x1/2 Phil. Truss Hd.. Type T	4
2	112007	(盒盖)胶垫	Gasket	1
3	288465	小分线盒盖	Lid & Gasket Assy. (Incls Item	1
4	NS-018-28	螺母	Jam Nut 1/2 – 20 Hex	1
5	WL-014-31	防松垫圈	Lockwasher 1/2 External Shake proof (SST)	1
6	WS-010-40	垫圈	Washer	1
7	743870	小分线盒(水箱用)	Junction Box – Auto Fill	1
8	FE-024-57	1/2" 塑料管接头(包括锁紧垫圈)	Connector – Straight 1/2(incls Gasket).	1
9	PB-004-08	塞子 (小线盒用)	Tap	1
10	7152503-001	浮子开关	Float Switch	1

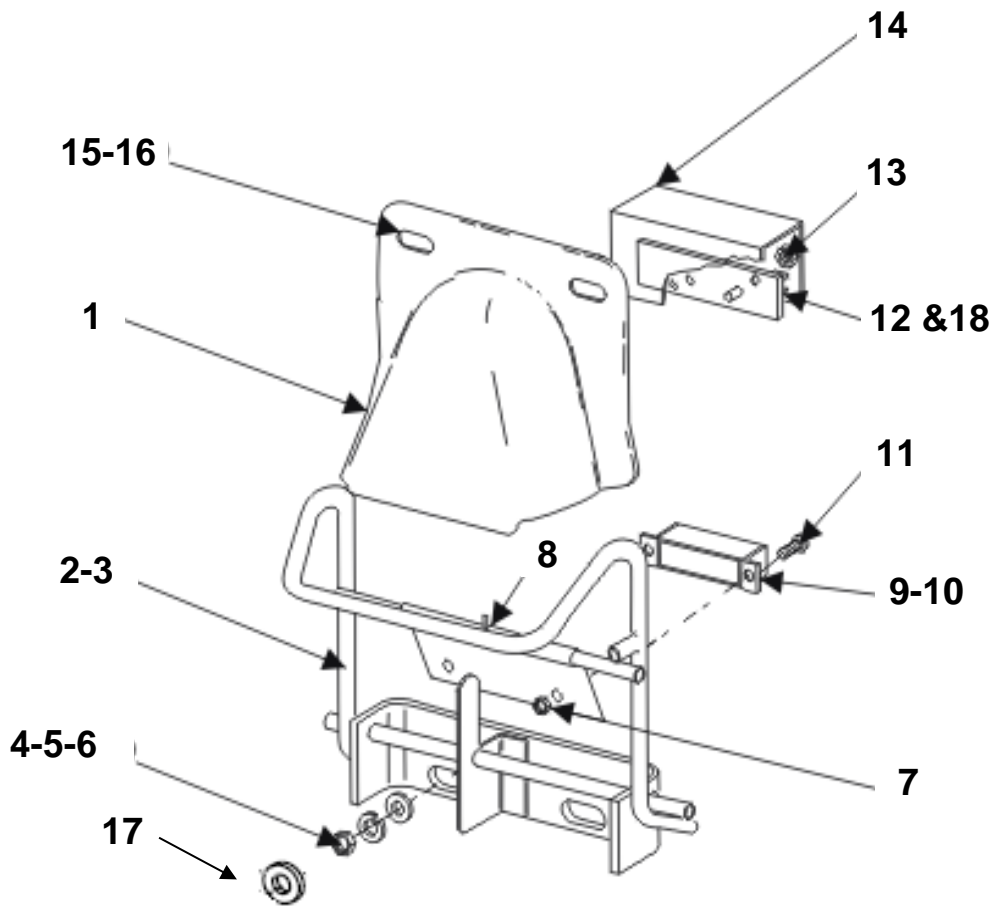

Fig.4 触碰开关机构
ACTUATOR MECHANISM

C44BP SERIES DISHWASHER REPLACEMENT PARTS

触碰开关机构 (自动延时喷淋机型)
ACTUATOR MECHANISM (Auto time-lapse rinse type)

序号 No.	物料号 Part No	名称	Description	数量 Qty
1	436835	小靴罩	Shroud	1
2	742318	磁开关支架(R-L)	Actuator (R-L)	1
3	742319	磁开关支架(L-R)	Actuator (L-R)	1
4	WL-006-23	防松垫圈	Lockwasher 5/16 Medium (SST)	2
5	WS-017-08	垫圈	Washer	2
6	NS-015-11	螺母 5/16-18 Hex	Nut 5/16-18 Hex.	2
7	NS-031-50	螺母6-32 Hex (SST)	Stop Nut 6-32 Hex (SST)	2
8	PC-005-07	开口销钉	Cotter Pin 3/32 x1/2	1
9	290160	磁铁	Magnet	1
10	742026	磁铁盒	Retainer – Magnet	1
11	SC-021-08	螺钉 6-32 x3/8 Rd. Hd. (SST)	Mach. Screw 6-32 x3/8 Rd. Hd. (SST)	2
12	02-229517-002	磁开关	Read Switch	1
13	NS-031-50	螺母6-32 Hex (SST)	Stop Nut 6-32 Hex (SST)	2
14	270996	磁开关塑料护片	Insulator – Switch	4
15	NS-029-01	螺母1/4- 20	Wing Nut 1/4- 20	2
16	WL-006-17	防松垫圈	Lockwasher 1/4 Medium	2
17	WS-029-05	垫片	Washer	2

触碰开关机构 (机械触碰喷淋机型)
ACTUATOR MECHANISM (Mechanical touch rinse type)

序号 No.	物料号 Part No	名称	Description	数量 Qty
1	436835	小靴罩	Shroud	2
2	742318	磁开关支架(R-L)	Actuator (R-L)	2
3	742319	磁开关支架(L-R)	Actuator (L-R)	2
4	WL-006-23	防松垫圈	Lockwasher 5/16 Medium (SST)	4
5	WS-017-08	垫圈	Washer	4
6	NS-015-11	螺母 5/16-18 Hex	Nut 5/16-18 Hex.	4
7	NS-031-50	螺母6-32 Hex (SST)	Stop Nut 6-32 Hex (SST)	4
8	PC-005-07	开口销钉	Cotter Pin 3/32 x1/2	2
9	290160	磁铁	Magnet	2
10	742026	磁铁盒	Retainer – Magnet	2
11	SC-021-08	螺钉 6-32 x3/8 Rd. Hd. (SST)	Mach. Screw 6-32 x3/8 Rd. Hd. (SST)	4
12	02-229517-002	磁开关	Read Switch	4
	02-229517-002	磁开关	Read Switch	2
13	NS-031-50	螺母6-32 Hex (SST)	Stop Nut 6-32 Hex (SST)	4
14	270996	磁开关塑料护片	Insulator – Switch	2
15	NS-029-01	螺母1/4- 20	Wing Nut 1/4- 20	4
16	WL-006-17	防松垫圈	Lockwasher 1/4 Medium	4
17	WS-029-05	垫片	Washer	4
18	892896	磁开关	Read Switch	4

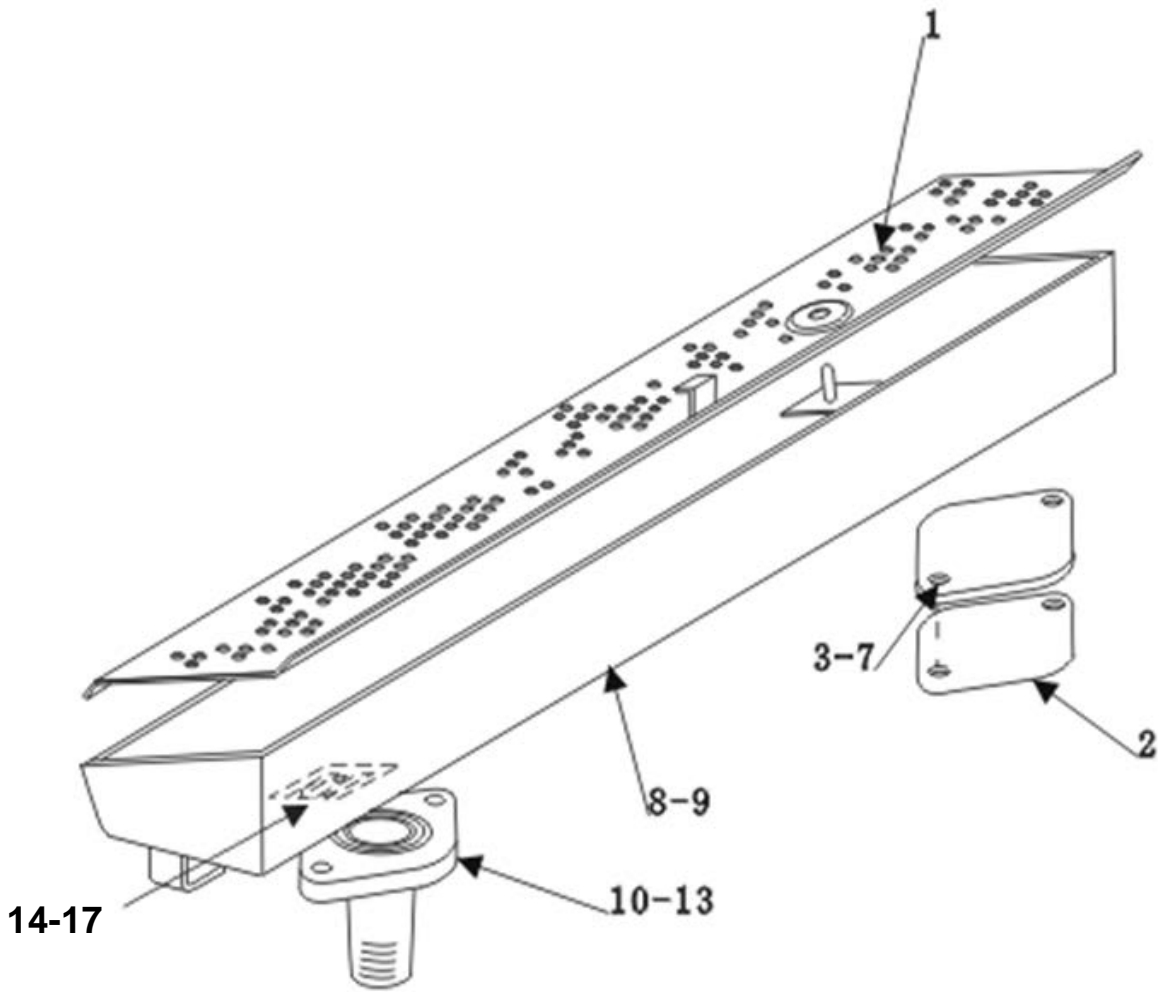

Fig.4.1 喷淋溢流盘
RINSE DRAIN-OFF PAN

C44BP SERIES DISHWASHER REPLACEMENT PARTS

喷淋溢流盘
RINSE DRAIN-OFF PAN

序号 No.	物料号 Part No	名称	Description	数量 Qty
1	742336	冲洗盒盖焊件	Strainer	1
2	276407	胶垫	Gasket – Rinse Pipe	1
3	742219	堵孔片	Flange	1
4	SC-041-12	螺钉 5/16 – 18 x7/8 Hex Hd	Cap Screw 5/16 – 18 x7/8 Hex Hd	2
5	WS-029-05	垫圈	Washer	2
6	WL-006-23	防松垫圈	Lockwasher 5/16 Medium (SST)	2
7	NS-015-11	螺母 5/16-18 Hex	Nut 5/16-18 Hex	2
8	742317	冲洗盒焊件(R-L)	Rinse Pan Assy. (R-L)	1
9	742315	冲洗盒焊件(L-R)	Rinse Pan Assay (L-R)	1
10	475056	冲洗排水嘴	Flange & Nipple Assay	1
11	436827	冲洗排水胶垫	Gasket	1
12	WL-006-23	防松垫圈	Lockwasher 5/16 Medium (SST).	2
13	NS-015-11	螺母 5/16-18 Hex	Nut 5/16-18 Hex.	2
14	742192	山字板	Panel	1
15	WS-017-06	垫片	Washer	2
16	WL-006-17	防松垫圈	Lock washer	2
17	NS-015-01	螺母	Nut	2

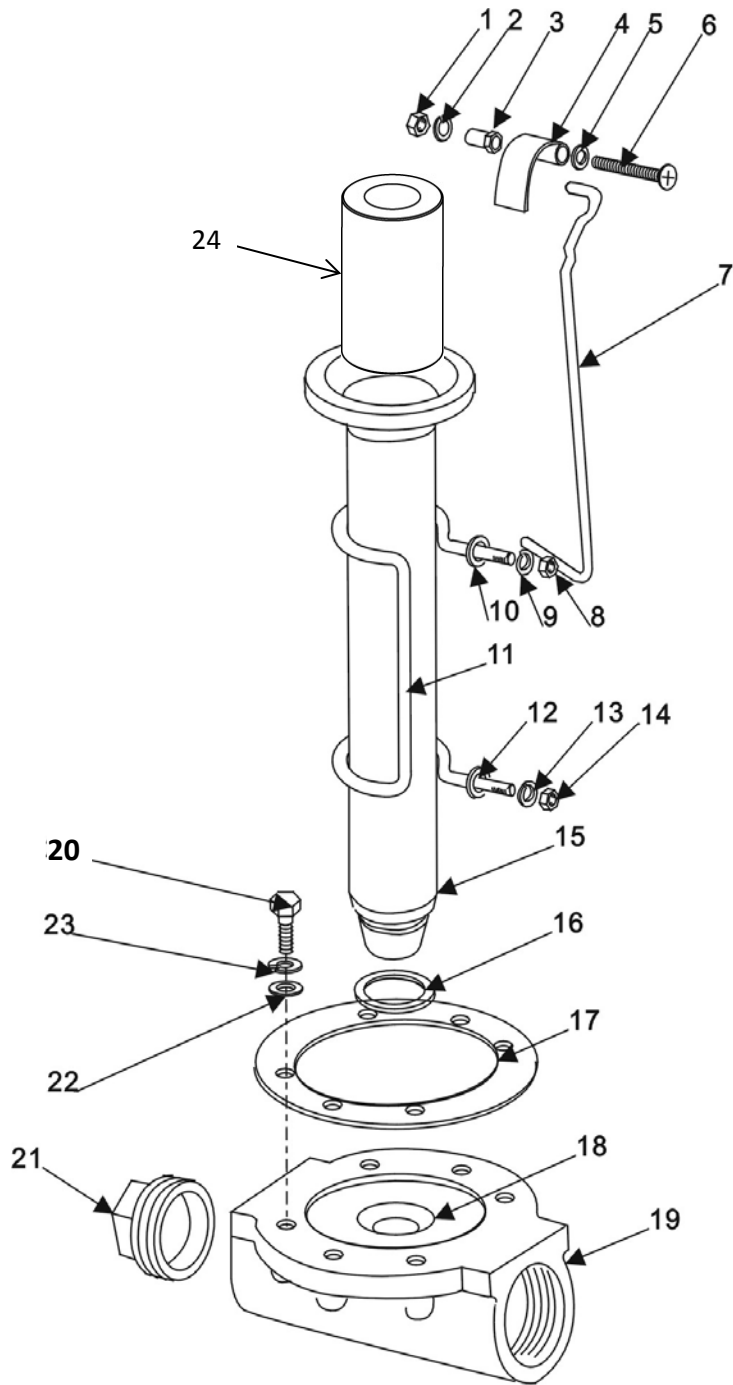

Fig.5 排水部分
DRAIN UNIT

C44BP SERIES DISHWASHER REPLACEMENT PARTS

排水部分
DRAIN UNIT

序号 No.	物料号 Part No	名称	Description	数量 Qty
1	NS-051-01	螺母 1/4-20 Hex	Nut 1/4 20 Hex (SST)	1
2	WL-006-17	防松垫圈	Lockwasher 1/4 Medium	1
3	119116-C1	门把手销钉	Axle – Drain Lever	1
4	742095	排水扳手焊件	Drain Lever (RH)	1
5	WS-022-01	垫圈	Washer	1
6	SCH-M6-35	螺钉 M6x35 Rd	Screw M6x35 Rd.	1
7	270953	排水提杆	Lift Rod Overflow	1
8	NS-M6	螺母 M6	Nut M6	2
9	WL-006-23	防松垫圈	Lockwasher 5/16 Medium (SST)	1
10	WS-017-01	垫圈	Washer	2
11	270952	支撑架	Retainer	4
	270952-3	支撑架	Retainer	1
12	WS-017-01	垫圈	Washer.	2
13	WL-006-23	防松垫圈	Lockwasher 5/16 Medium (SST)	1
14	NS-015-11	螺母 5/16-18 Hex	Nut 5/16-18 Hex	2
15	119099-2	溢流管	Tube- Overflow	1
16	67500-120	O型圈	O Ring	1
17	289464	排水口胶垫	Gasket – Drain	1
18	270947	排水三通钢套	Sleeve – Drain Body	1
19	289465	排水三通	Drain Body	1
20	SC-041-10	螺钉 3/8-16 x 1 Hex Hd. (SST)	Cap Screw 3/8-16 x 1 Hex Hd. (SST)	6
21	FP-028-32	管堵	Pipe Plug 2 Sq. Hd	1
22	WS-006-44	垫圈	Washer	6
23	WL-006-28	防松垫圈	Lockwasher 3/8 –16 x1 Hex Hd. (SST)	6
24	743910	溢流管加长套	Overflow Tube	1

C44BP SERIES DISHWASHER REPLACEMENT PARTS

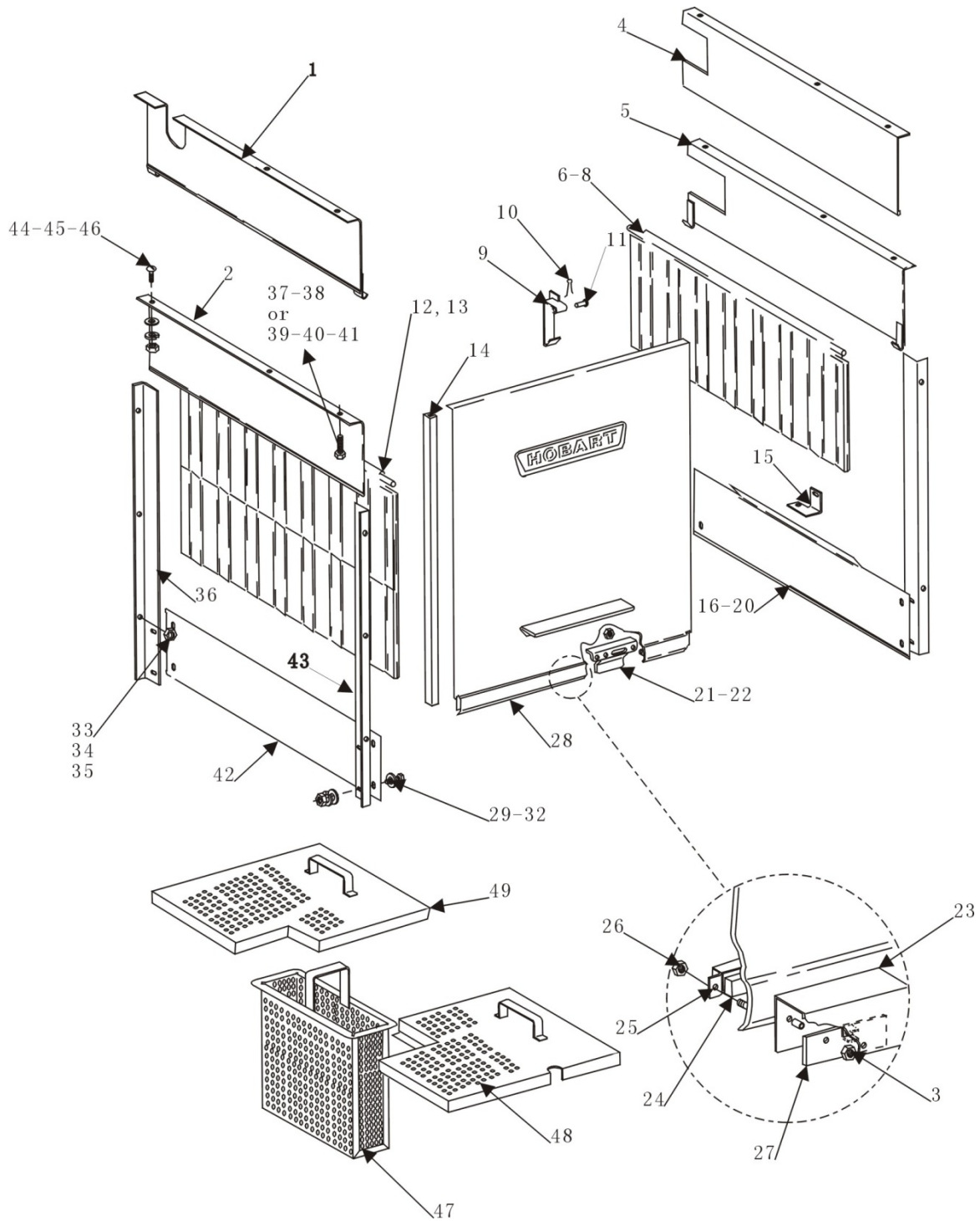

**Fig.6 门、门帘、隔板及滤网
DOOR, CURTAINS, Baffles, AND STRAINERS**

门、门帘、隔板及滤网 DOOR, CURTAINS, BAFFLES, AND STRAINERS

序号 No.	物料号 Part No	名称	Description	数量 Qty
1	742334	左上隔板焊件(R-L)	Baffle – Unloading (R-L)	1
2	742326	左上隔板焊件(L-R)	Baffle - Loading (L-R)	1
3	NS-031-50	螺母6-32 Hex (SST)	Stop Nut 6-32 Hex (SST)	2
4	742335	右上隔板焊件(R-L)	Baffle – Loading (R-L)	1
5	742302	右上隔板焊件(L-R)	Baffle – Unloading (L-R).	1
6	120151-1	小门帘	Splash Curtain	1
7	120151-1	小门帘(Gas heat)	Splash Curtain. (Gas heat)	1
8	742222	门帘棍	Curtain Rod	2
9	742312	门钩焊件	Catch – Door	1
10	PC-005-02	开口销	Cotter Pin 1/16 x1/2 (SST)	1
11	12114	门钩销钉	Pin	1
12	271084	门帘	Splash Curtain	2
13	742222	门帘棍	Curtain Rod	2
14	112378-49	门条	Door Slide	2
15	742158	右下隔板支撑(ONLY L-R)	Bracket (ONLY L-R)	1
16	742160	右下隔板(ONLY L-R)	Baffle (ONLY L-R)	1
17	SC-041-05	螺钉1/4 –20 x 5/8 Hex Hd. (SST)	Cap Screw 1/4 –20 x 5/8 Hex Hd. (SST).	3
18	WL-006-17	防松垫圈	Lockwasher 1/4 Medium	3
19	WS-017-06	垫圈	Washer	3
20	NS-015-01	螺母1/4 – 20 Hex	Nut 1/4 – 20 Hex (SST)	6
21	328065	门挡片	Actuator – Lift Drain	1
22	NS-031-21	螺母1/4-20 Hex	Stop Nut – Special 1/4-20 Hex	2
23	270996	磁开关塑料护片	Insulator – Switch	1
24	290160	磁铁	Magnet	2
25	742026	磁铁盒	Retainer – Magnet	2
26	NS-031-50	螺母 6-32 Hex (SST)	Stop Nut 6-32 Hex (SST)	2
27	02-229517-002	磁开关	Reed Mounting Board Assy	1
28	742321	门焊件	Door	1
29	SC-041-05	螺钉1/4 –20 x 5/8 Hex Hd. (SST)	Cap Screw 1/4 –20 x 5/8 Hex Hd. (SST)	4
30	WS-017-06	垫圈	Washer	8
31	WL-006-17	防松垫圈	Lockwasher 1/4 Medium	4
32	NS-015-01	螺母1/4–20 Hex (SST)	Nut 1/4–20 Hex (SST)	4
33	WS-022-01	垫圈	Washer	9
34	WL-006-17	防松垫圈	Lockwasher 1/4 Medium	9
35	NS-015-01	螺母1/4–20 Hex (SST)	Nut 1/4–20 Hex (SST)	9
36	742161	洗室内竖板	Baffle - Vertical	2
37	WL-006-17	防松垫圈	Lockwasher 1/4 Medium	4
38	SC-041-50	螺钉1/4 –20 x 5/8 Hex Hd. (SST)	Cap Screw 1/4 –20 x 5/8 Hex Hd. (SST)	4
39	WS-022-01	垫圈	Washer	4
40	WL-006-17	防松垫圈	Lockwasher 1/4 Medium	4
41	NS-015-01	螺母1/4–20 Hex (SST)	Nut 1/4–20 Hex (SST)	4
42	742159	左下隔板	Baffle – LH Lower	1
43	742161	洗室内竖板	Baffle - Vertical	1
44	SC-053-41	螺钉1/4-20 x 1/2 Truss Hd. (SST)	Mach. Screw 1/4-20 x 1/2 Truss Hd. (SST)	2
45	WL-006-17	防松垫圈	Lockwasher 1/4 Medium	2
46	NS-015-01	螺母1/4–20 Hex (SST)	Nut 1/4–20 Hex (SST)	2
47	742311	深滤网焊件	Bucket – Strainer	1
48	742310	前滤网焊件	Strainer - Front	1
49	742309	后滤网焊件	Strainer – Rear	1

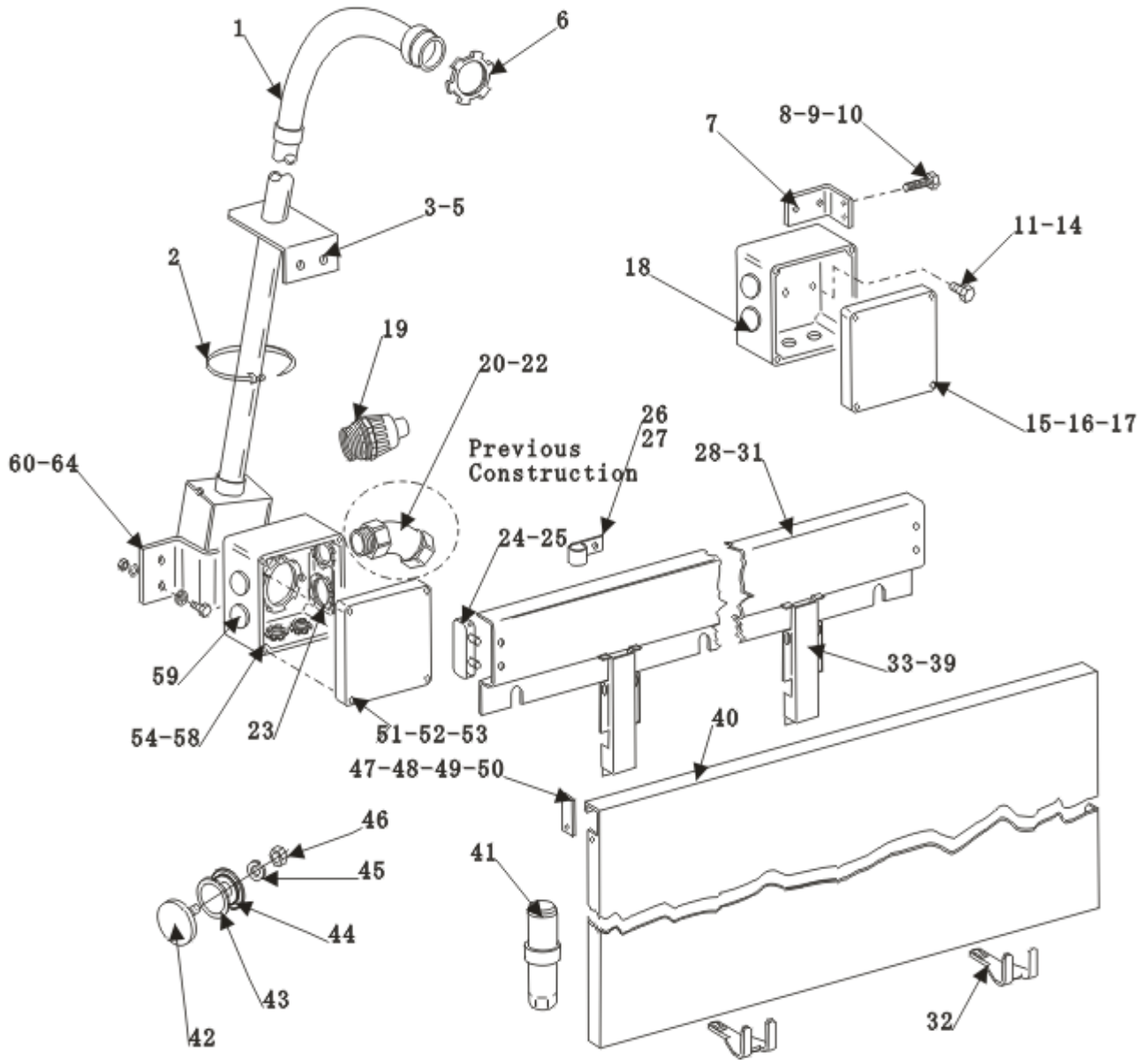

Fig.7 其他零件 (清洗部分)
MISCELLANEOUS

C44BP SERIES DISHWASHER REPLACEMENT PARTS

其他零件 (清洗部分)
MISCELLANEOUS

序号 No.	物料号 Part No	名称	Description	数量 Qty
1	274232-C	PVC穿线管(国产)(包括支架)	Conduit – PVC(Incls. Bracket)..	1
2	122577-2	线卡子	Wire Tie	2
3	SC-041-50	螺钉 1/4-20 x 1/2 Hex Hd	Cap Screw 1/4-20 x 1/2 Hex Hd	2
4	WL-006-17	防松垫圈	Lockwasher 1/4 Medium	2
5	NS-015-01	螺母1/4- 20 Hex (SST)	Nut 1/4- 20 Hex (SST)	2
6	FE-009-07	锁母1 1/4	Lock Nut 3/4	2
7	742215	右后侧分线盒支板	Bracket	1
8	SC-041-12	螺钉 5/16-18 x 7/8 Hex Hd.	Cap Screw 5/16-18 x 7/8 Hex Hd	2
9	WL-006-23	防松垫圈	Lockwasher 5/16 Medium	2
10	NS-015-11	螺母 5/6 -18 Hex (SST)	Nut 5/6 -18 Hex (SST)	2
11	SC-041-05	螺钉 1/4-20 x 5/8 Hex Hd	Cap Screw 1/4-20 x 5/8 Hex Hd	2
12	WS-003-49	垫圈	Washer	2
13	WL-006-17	防松垫圈	Lockwasher 1/4 Medium	2
14	NS-015-01	螺母1/4- 20 Hex (SST)	Nut 1/4-20 Hex (SST)	2
15	288465	小分线盒盖	Lid & Gasket Assy. (Incls Item 16)	1
16	112007	胶垫	Gasket	1
17	SD-012-20	螺钉(T型,8-32x1/2)...	Self- Tapping Screw 8-32 x1/2 Phil. Truss Hd., Type T	4
18	270923-2	分线盒(R.H)	Box – Junction (R.H)	1
19	FE-024-58	3/4"接头(O型圈及锁母)	Connector 3/4"(Incls. O Ring & Lock Nut)	1
20	FE-008-44	45Deg 3/4"金属接头 (现已改用item19)	Connector 3/4"((Incls. O Ring & Lock Nut).(Replaced by item19)	2
21	FE-008-11	密封圈	Ring-Seal	2
22	FE-006-06	锁母3/4	Nut	2
23	FE-024-59	1"接头(O型圈及锁母)	Connector 1" ((Incls. O Ring & Lock Nut).	2
24	271057	护线槽端堵	Cap – Wire way	2
25	SD-007-38	螺钉8 x 1/4 Phil. Bind Hd., Type B	Self-Tapping Screw 8 x 1/4 Phil. Bind Hd., Type B	2
26	294677-3	线卡环	Clamp – Wire (3/4 I.D)	6
27	NS-047-94	螺母	Lock Nut Special 3/16	6
28	742137	水平护线槽	Panel – Front Trim.	1
29	WS-017-06	垫圈	Washer	3
30	WL-006-17	防松垫圈	Lockwasher 1/4 Medium	3
31	NS-015-01	螺母1/4-20 Hex (SST)	Nut 1/4-20 Hex (SST)	3
32	742201	前护板挂钩	Support	2
33	742136	垂直护线套	Wire way – Vertical	2
34	SC-021-22	螺钉	Screw	2
35	WL-006-07	防松垫圈	Lockwasher #10 Medium	2
36	WS-017-06	垫圈	Washer	4
37	WL-006-17	防松垫圈	Lockwasher 1/4 Medium	4
38	NS-015-01	螺母1/4-20 Hex (SST)	Nut 1/4-20 Hex (SST)	4
39	WS-019-19	垫圈	Washer	2
40	742139	前护板(C44B&C44BW)	Panel – Front Trim (C44B&C44BW)	1

C44BP SERIES DISHWASHER REPLACEMENT PARTS

其他零件 (清洗部分) MISCELLANEOUS

序号 No.	物料号 Part No	名称	Description	数量 Qty
41	288946-C	可调底脚(国内件)	Food - Adjustable (China)	4
42	119244	内孔堵片	Cap & Stud Assy	1
43	67500-31	O型圈	O Ring	1
44	119254	外孔堵片	Retainer – Cap & Stud	1
45	WL-006-17	防松垫圈	Lockwasher 1/4 Medium	1
46	NS-015-01	螺母1/4-20 Hex (SST)	Nut 1/4-20 Hex (SST)	1
47	742138	前护板两端堵片	Cover – Panel Notch	2
48	SC-053-05	螺钉10-24 x3/8 Phil. Truss Hd.	Mach. Screw 10-24 x3/8 Phil. Truss Hd	2
49	WS-019-06	垫圈	Washer	2
50	NS-031-16	螺母10-24 hex (SST)	Stop Nut 10-24 hex (SST)	2
51	288465	盒盖(包括52)	Lid & Gasket Assy. (Incls. Item 52)	1
52	112007	垫圈	Gasket.	1
53	SD-012-20	螺丝(T型,8-32x1/2)	Self – Tapping Screw 8-32x1/2 Phil. Truss Hd. Type T	4
54	270923-1	小分线盒(左侧)	Box – Junction (LH)	1
55	SC-041-05	螺钉1/4 – 20 x5/8 Hex Hd. (SST)	Cap Screw 1/4 – 20 x5/8 Hex Hd. (SST)	2
56	WS-003-49	垫圈	Washer	2
57	WL-006-17	防松垫圈..	Lockwasher 1/4 Medium	2
58	NS-015-01	螺母1/4-20 Hex (SST)	Nut 1/4-20 Hex (SST)	2
59	PB-004-08	塑料堵	Plug	5
60	742144	左后侧分线盒支板	Bracket	1
61	SC-041-12	螺钉5/16 – 18 x 7/8 Hex Hd	Cap Screw 5/16 – 18 x 7/8 Hex Hd	2
62	WS-017-08	垫圈	Washer	2
63	WL-006-23	防松垫圈	Lockwasher 5/16 Medium (SST)	2
64	NS-015-11	螺母 5/16 – 18 Hex	Nut 5/16 – 18 Hex	2

C44BP SERIES DISHWASHER REPLACEMENT PARTS

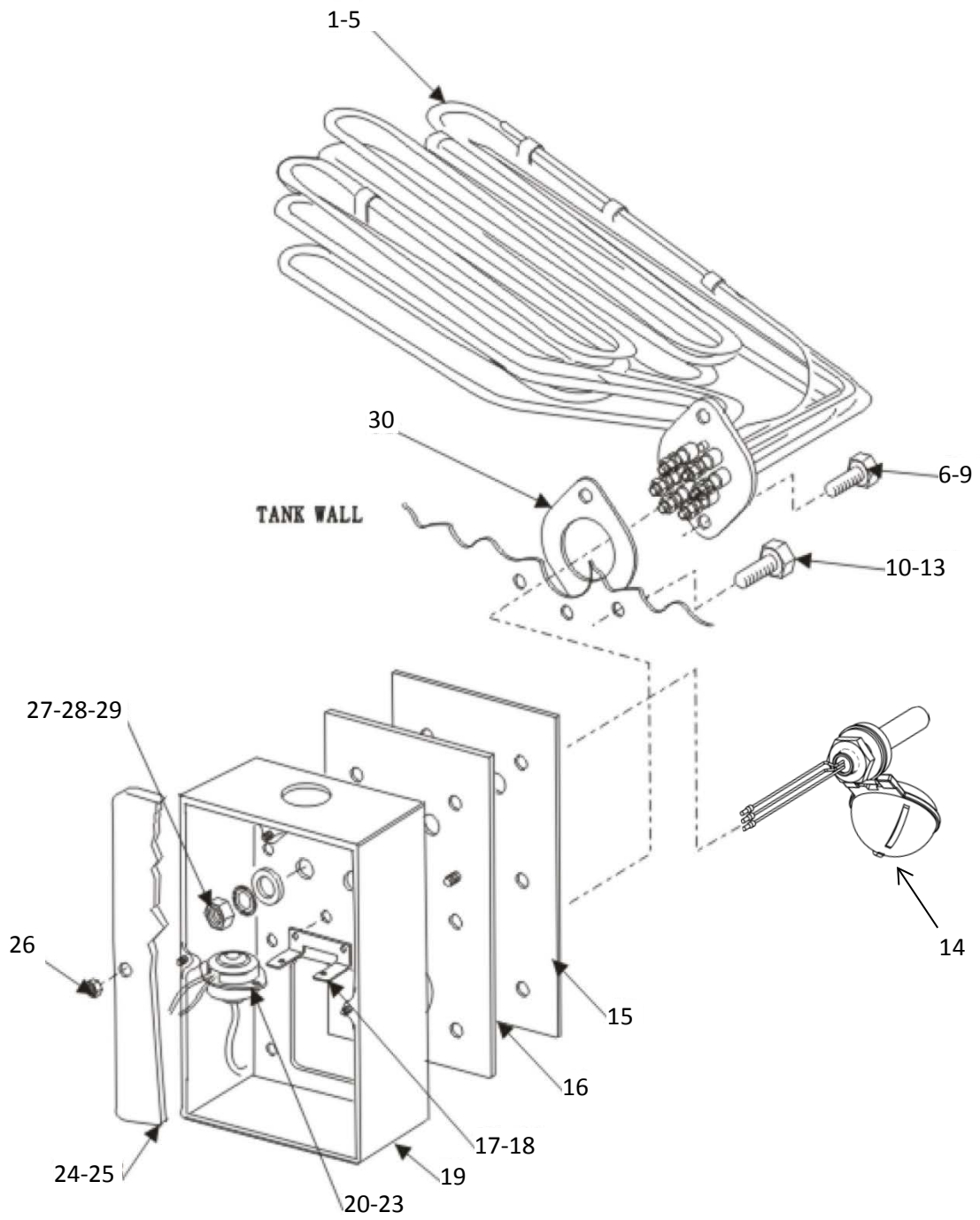

**Fig.8 电加热及水位控制
ELECTRIC HEAT**

电加热及水位控制 ELECTRIC HEAT

序号 No.	物料号 Part No	名称	Description	数量 Qty
1	473275-1	电热管 (200v/3Ph, 7.5kw)	Heater – tank Electric (200v/3Ph, 7.5kw)	1
2	473275-2	电热管 (220v/1Ph, 7.5kw)	Heater – tank Electric (220v/1Ph, 7.5kw)	1
3	473275-6	电热管 (380v/50Hz/3Ph, 7.5kw)	Heater – tank Electric (380v/50Hz/3Ph, 7.5kw)	1
4	7152081	电热管 (380v/3Ph, 15kw)	Heater – tank Electric (380v/3Ph, 15kw)	1
5	7152081-1	电热管 (220v/3Ph, 15kw)	Heater – tank Electric (220v/3Ph, 15kw)	1
6	SC-041-13	螺钉5/16-18 x1 Hex Hd. (SST)	Cap Screw 5/16-18 x1 Hex Hd. (SST)	2
7	WS-017-08	垫圈	Washer	2
8	WL-006-23	防松垫圈	Lockwasher 5/16 Medium (SST)	2
9	NS-015-11	螺母5/16 – 18 Hex	Nut 5/16 – 18 Hex	2
10	SC-041-13	螺钉5/16-18 x1 Hex Hd. (SST)	Cap Screw 5/16-18 x1 Hex Hd. (SST)	6
11	WS-029-05	垫圈	Washer	12
12	WL-006-23	防松垫圈	Lockwasher 5/16 Medium (SST)	6
13	NS-015-11	螺母5/16 – 18 Hex	Nut 5/16 – 18 Hex	6
14	7152503-001	浮子开关	Float Switch	1
15	271109	胶垫	Gasket – Mounting	1
16	742325	大线盒垫板焊件	Plate – Mounting	1
17	742212	热敏件支架.	Bracket – Thermostat	1
18	NS-031-15	止退螺母	Stop Nut 10-24 Hex (SST)	2
19	742337	加热盒焊件	Box - Electric	1
20	271123	热敏件	Protector- High Limit	1
21	SC-021-08	螺母6-32 x 3/8 Rd. Hd. (SST)	Mach. Screw 6-32 x 3/8 Rd. Hd. (SST)	2
22	NS-031-50	螺母6-32 Hex (SST)	Stop Nut 6-32 Hex (SST)	2
23	293946	护套	Sleeve	1
24	742228	电加热盒盖	Lid & Gasket Assy. (Incls item30)	1
25	112005	胶垫	Gasket (Lid)	1
26	NS-031-15	螺母	Nut	4
27	WS-010-40	垫圈	Washer	2
28	WL-014-31	防松垫圈	Lockwasher 1/2 External Shake proof (SST).	2
29	NS-018-28	止退螺母	Jam Nut 1/2 – 20 Hex	2
30	293598	胶垫	Gasket – heater Mounting	1
	294357-1	白接插件	Housing – Connector (Nat).	AR
	294357-2	黑接插件	Housing – Connector (Black)	AR

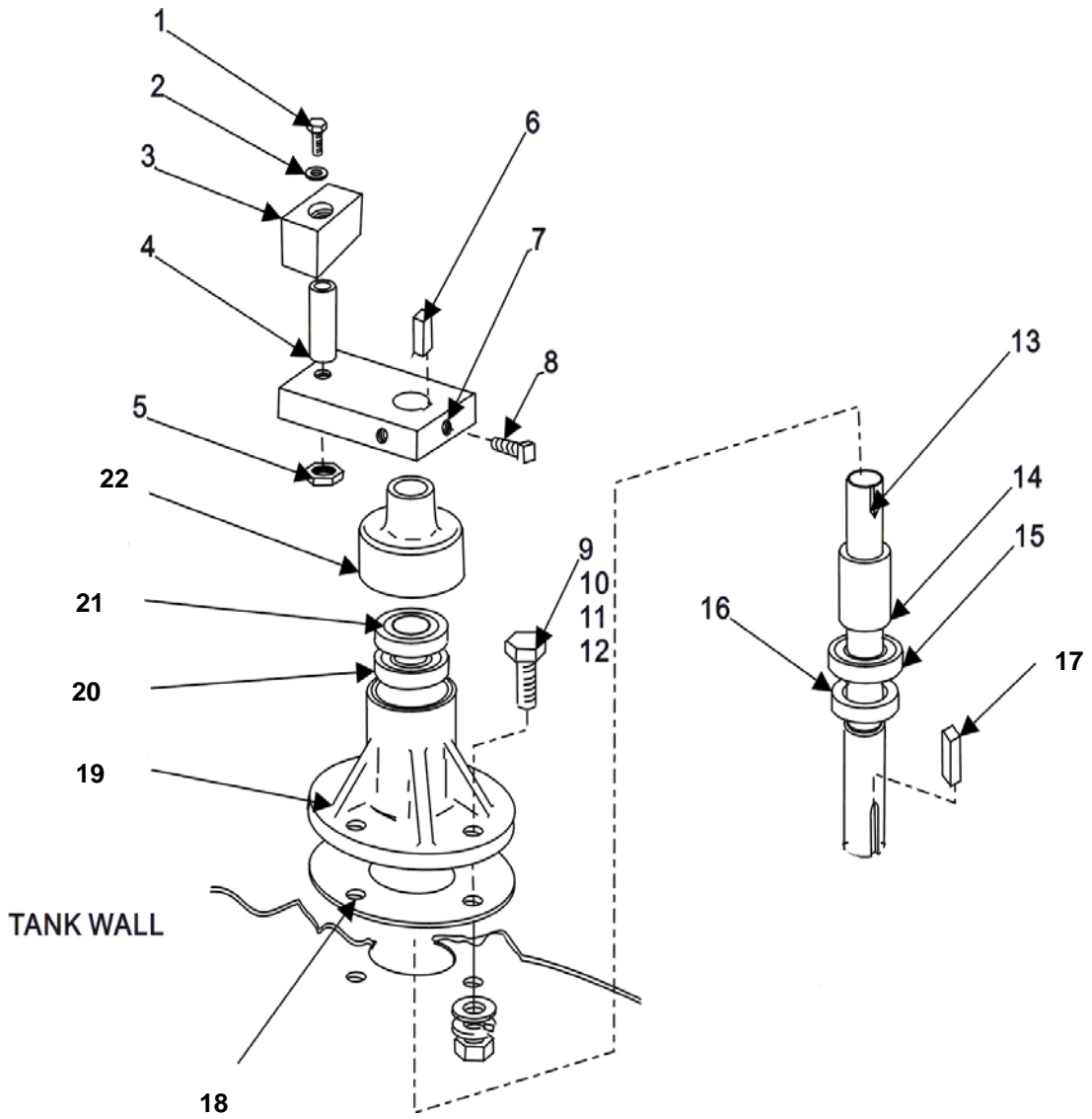

Fig.9 输送传动部件
CONVEYOR DRIVE TRAIN

C44BP SERIES DISHWASHER REPLACEMENT PARTS

输送传动部件
CONVEYOR DRIVE TRAIN

序号 No.	物料号 Part No	名称	Description	数量 Qty
1	SC-041-20	螺钉5/16 – 18 x 2 1/8 Hex Hd	Cap Screw 5/16 – 18 x 2 1/8 Hex Hd	1
2	WS-017-08	垫圈	Washer	1
3	474660	偏心滑块	Slide – Drive Crank	1
4	437061	小套筒	Spacer – Bearing	1
5	NS-032-35	螺母 5/16 – 18 Flex loc	Stop Nut 5/16 – 18 Flex loc	1
6	12430-39	键 3/16 Sq. x3/8 Lg	Key 3/16 Sq. x3/8 Lg.	1
7	270943	曲柄	Arm – Crank	1
8	SC-050-01	螺丝 1/4-20x1/2方头	Set Screw 1/4-20x1/2 Square Hd. Cup Pt	2
9	SC-041-13	螺钉5/16 –18 x1 Hex Hd. (SST)	Cap Screw 5/16 –18 x1 Hex Hd. (SST)	4
10	WS-017-08	垫圈	Washer	4
11	WL-006-23	防松垫圈	Lockwasher 5/16 Medium (SST)	4
12	NS-015-11	螺母5/16 – 18 hex	Nut 5/16 – 18 hex	4
13	270937	偏心轴	Shaft – Crank.	1
14	436879	小套筒	Spacer – Bearing	1
15	BB-021-19	滚珠轴承	Ball Bearing – Hoover NSK 6003	1
16	270939	密封	Seal – Lower Housing	1
17	12430-40	键 3/16 Sq. x 3/4Lg	Key 3/16 Sq. x 3/4Lg	1
18	270942	偏心轴胶垫	Gasket	1
19	274749	偏心轴总成(包括 13-16,20-22)	Housing Assay (incl. Item 13-16,20-22)	1
20	BB-021-19	滚珠轴承	Ball Bearing – Hoover NSK 6003	1
21	270940	密封	Seal – upper Housing	1
22	274748	密封	Seal Labyrinth	1

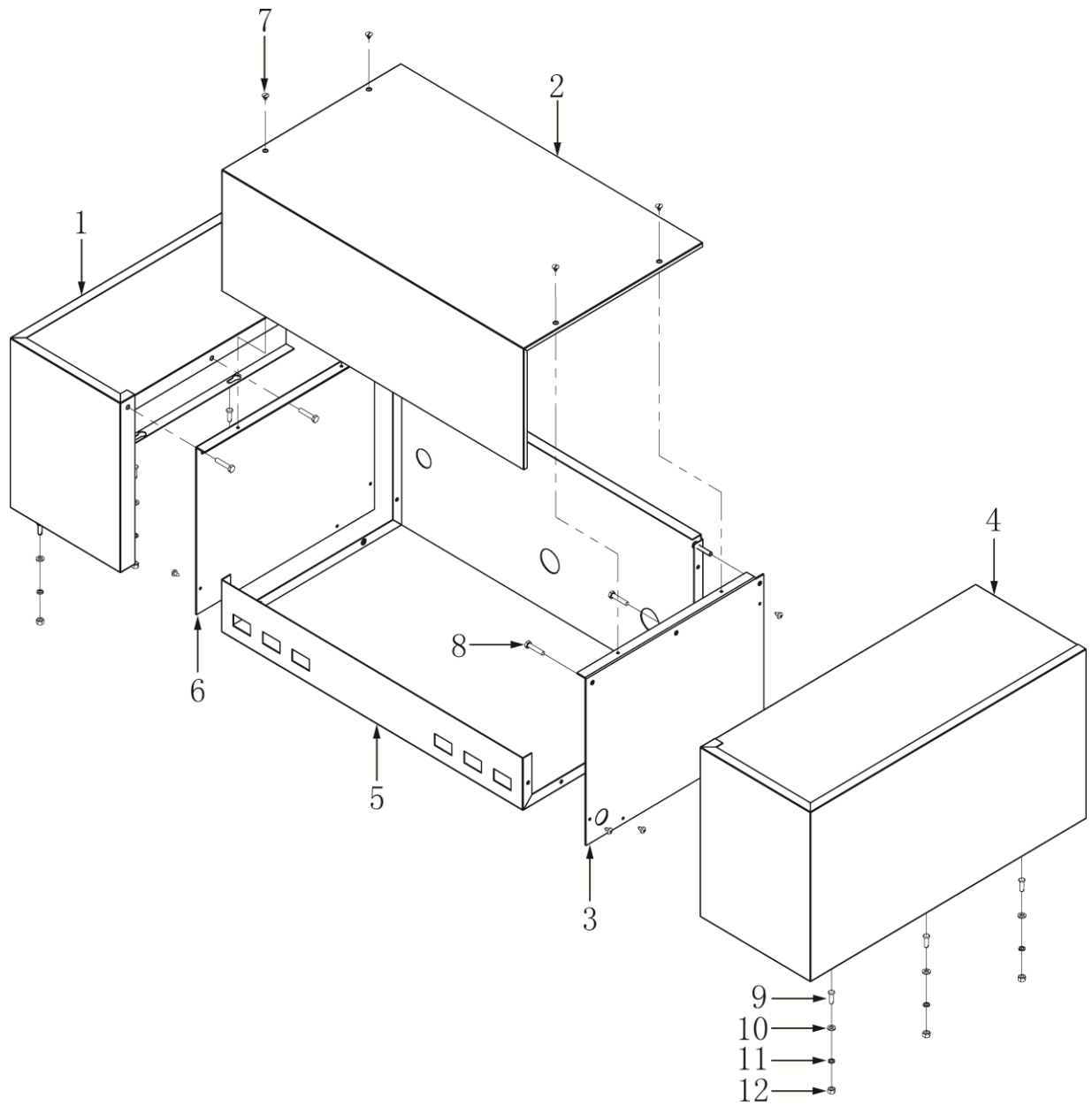

Fig.10 控制盒及加热器外罩
COMPONENT PANEL

**控制盒及加热器外罩
COMPONENT PANEL**

序号 No.	物料号 Part No	名称	Description	数量 Qty
1	7152085	左加热器外罩焊件	Left Hood-Booster	1
2	7152015	控制盒盖板焊件	Cover-Control Box	1
3	7152083	右基板	Right-Base Plate	1
4	7152013	右加热器外罩焊件	Right Hood-Booster	1
5	7152076	控制盒底焊件	Control Box.	1
6	7152084	左基板	Left-Base Plate	1
7	ST4.8-10	自攻螺钉	Self-tapping Screw	14
8	SCH-M6-10	螺栓	Cap Screw	6
9	7152010	销轴	Pin	6
10	WS-M6	垫圈	Washer	6
11	WL-M6	防松垫圈	Lockwasher	6
12	NS-M6	螺母	Nut	6

控制盒面板组件 CONTROL BOX AND BOOSTER COVER

序号 No.	物料号 Part No	名称	Description	数量 Qty
1	7152504-001	进电端子排	Power Terminal	1
2	7152039	接线排	Terminal Block	1
3	743401	接触器32-NO	Contactactor 32-NO	1
4	743402	接触器09-NO	Contactactor 09-NO	1
5	743402	接触器09-NO	Contactactor 09-NO	1
6	7152036	热继电器 0.63-1.0 380V/50Hz-220V/380V/60Hz	Thermal relay 0.63-1.0 380V/50Hz-220V/380V/60Hz	1
	7152046	热继电器 1.0-1.6 220V/50Hz	Thermal relay 1.0-1.6 220V/50Hz	1
7	7152044	热继电器 2.5-4.0 380V/50Hz/60Hz	Thermal relay 2.5-4.0 380V/50Hz/60Hz	1
	7152045	热继电器 4.00-6.00 220V/50Hz/60Hz	Thermal relay 4.0-6.0 220V/50Hz/60Hz	1
8	7152508-001	接触器09-NC	Contactactor 09-NC	1
9	743402	接触器09-NO	Contactactor 09-NO	1
10	7152508-001	接触器09-NC	Contactactor 09-NC	1
11	02-301777-002	两相断路器	Breaker	1
12	7152504-002	控制端子排	Terminal-control	1
13	7159336-1	智能温控板组件	Thermal control board	1
14	7152038	断路器 60A/3P	Breaker 60A/3P	1
15	7152038	断路器 60A/3P	Breaker 60A/3P	1
16	743401	接触器32-NO	Contactactor 32-NO	1
17	743401	接触器32-NO	Contactactor 32-NO	1
18	743845	温控器 110℃	Thermostat 110℃	1
19	87711-241-1	定时开关	Switch-Rocker(Timer On/Off)	1
20	87711-228-1	启动开关	Switch-Rocker(Motor On/Off)	1
21	87711-198-1	电源开关	Switch-Rocker(Power On/Off)	1
22	7160583-001	继电器	Relay	1
23	7160734-002	挡水帘	Water-Screen	1

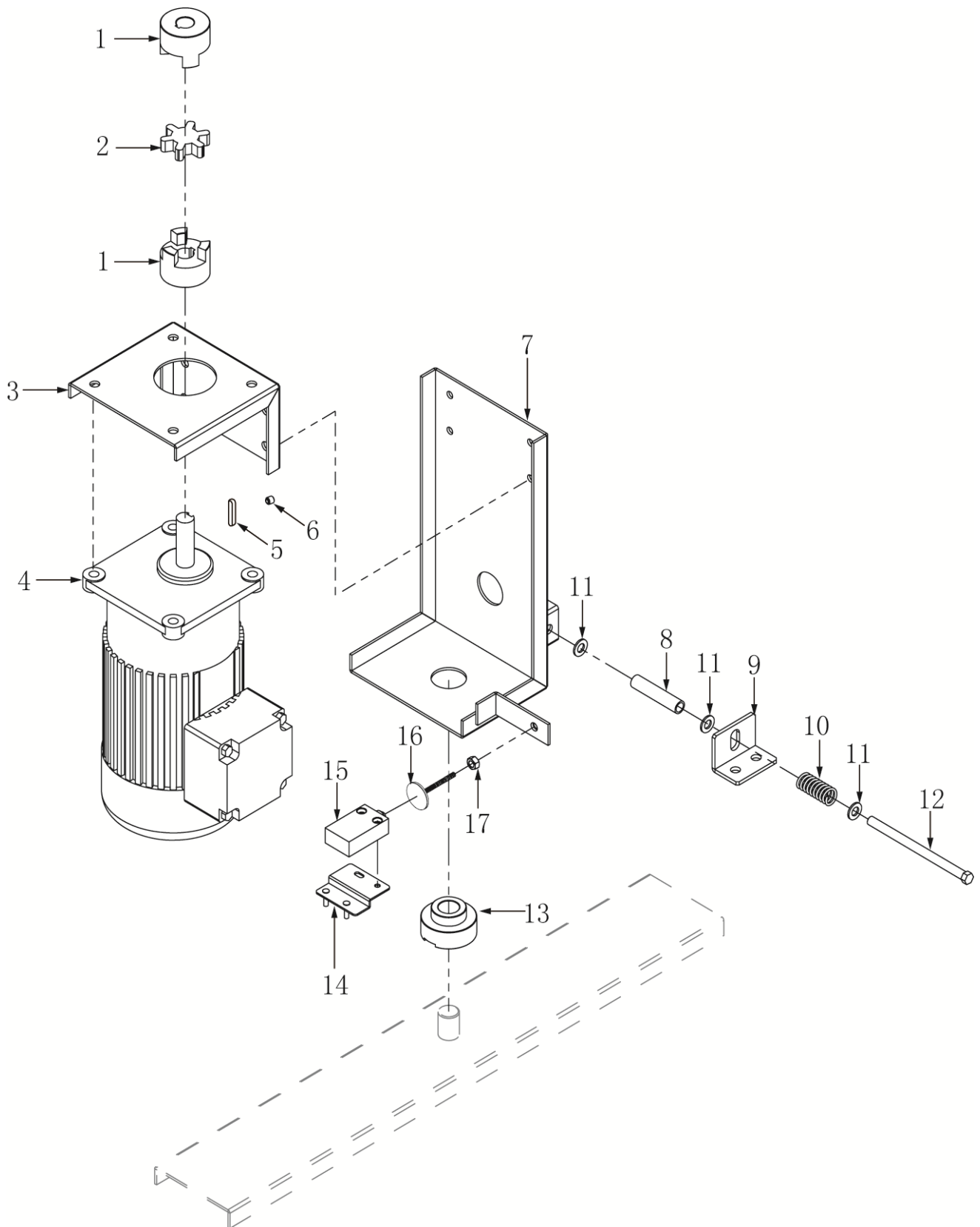
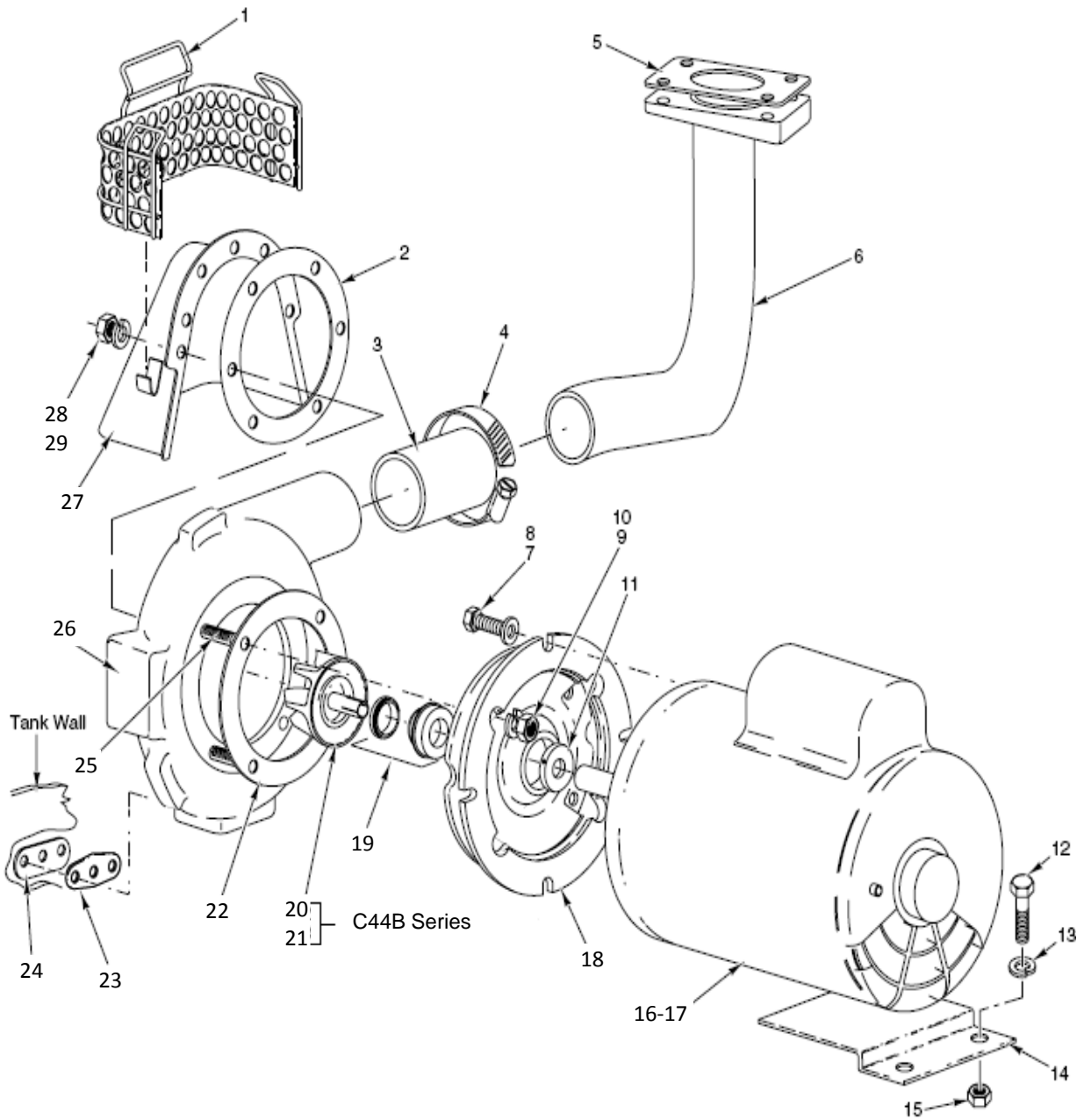

Fig. 12 传动马达
CONVEYOR DRIVE MOTOR

传动马达 CONVEYOR DRIVE MOTOR

序号 No.	物料号 Part No	名称	Description	数量 Qty
1	328083	联轴器	Coupling Motor	1
2	274228-2	减震块	Insert – Coupling Service (Love Joy)	1
3	7152027	电机过渡连接板	Bracket-Motor	1
4	437044-1	传动电机(200-230/460V,60Hz,3PH)	Motor - Conveyor (200-230/460V,60Hz,3PH)	1
	437044-4	传动电机(220/380V,50Hz,3PH)	Motor - Conveyor (220/380V,50Hz,3PH)	1
5	274231-57	平键 3/16x3/16x11/8Lg	Key 3/16x3/16x11/8Lg	1
6	SCH-M6-8	顶丝M6x8	Screw M6X8	1
7	742313	马达座焊件	Braket Motor	1
8	271083	小套筒	Spacer – Overload	1
9	436017	支撑片	Bracket – Load	1
10	436952	过载保护弹簧	Spring – Overload	1
11	WS-029-05	垫圈 8	Washer 8	3
12	SC120-72	弹簧螺杆 5/16 – 18 x4 1/2 Hex Hd	Cap Screw 5/16 – 18 x4 1/2 Hex Hd	1
13	270927	尼龙座	Pilot Bearing	1
14	742220	微动开关支座焊件	Bracket – Switch	1
15	87711-260	微动开关	Switch – Interlock	1
16	742314	止钮	Actuator-Switch	1
17	NS-M6	螺母 M6	Nut M6	1

C44BP SERIES DISHWASHER REPLACEMENT PARTS



**Fig. 13 清洗水泵
WASH MOTOR AND PUMP UNIT**

C44BP SERIES DISHWASHER REPLACEMENT PARTS

**清洗水泵
WASH MOTOR AND PUMP UNIT**

序号 No.	物料号 Part No	名称	Description	数量 Qty
1	328362	泵护网	Strainer-Pump	1
2	119050	垫圈	Gasket	1
3	328215	胶管	Hose-Discharge	1
4	542337	喉箍	Clamp-Hose	2
5	270968	胶垫	Gasket- Washer Pipe	1
6	742304	弯管焊件	Tube Discharge	1
7	SC-041-29	螺栓	Cap Screw 3/8-16x7/8 Hex Hd	4
8	WS-006-44	垫圈	Washer	4
9	WL-006-22	防松垫圈	LockWasher 5/16 Light	4
10	NS-015-11	螺母	Nut 5/16-18 Hex	4
11	274227-2	线卡子	Clamp	1
12	SC-041-05	螺栓	Cap Screw 1/4-16x5/8 Hex Hd	2
13	WL-007-15	防松垫圈	LockWasher 1/4	2
14	742218	马达托板	Bracket Motor Support	1
15	NS-015-01	螺母	Nut 1/4-20 Hex	2
16	274230-2	电机 (3Ph,60Hz)(2HP)	Motor (3Ph,60Hz)(2HP)	1
17	274230-4	电机 (3Ph,50Hz)(2HP)	Motor (3Ph,50Hz)(2HP)	1
18	274227-3	适配盘	Adapter	1
19	274227-6	轴封	Seal-Shaft	1
20	274227-7	叶轮(60Hz)	Impeller&Sleeve(60Hz)	1
21	274227-10	叶轮(50Hz)	Impeller&Sleeve(50Hz)	1
22	274227-4	垫圈	Gasket	1
23	119051	垫圈	Gasket.	2
24	812776	加强板	Panel	2
25	274227-5	螺钉	Stud	AR
26	274227-1	壳体	Pump Shell	1
27	742303	大靴罩焊件	Shroud	1
28	WL-006-23	防松垫圈	LockWasher 5/16 Medium	10
29	NS-015-11	螺母	Nut 5/16-18 Hex	10
	270950-2	大水泵(3ph,60hz)(2HP)(incls.items 7 thru 11,16,18,19,20,22,25&26)	Pump(3ph,60hz)(2HP)(incls.items 7 thru 11,16,18,19,20,22,25&26)	1
	270950-4	大水泵(3ph,50hz)(2HP)(incls.items 7 thru 11,17,18,19,21,22,25&26)	Pump(3ph,50hz)(2HP)(incls.items 7 thru 11,17,18,19,21,22,25&26)	1

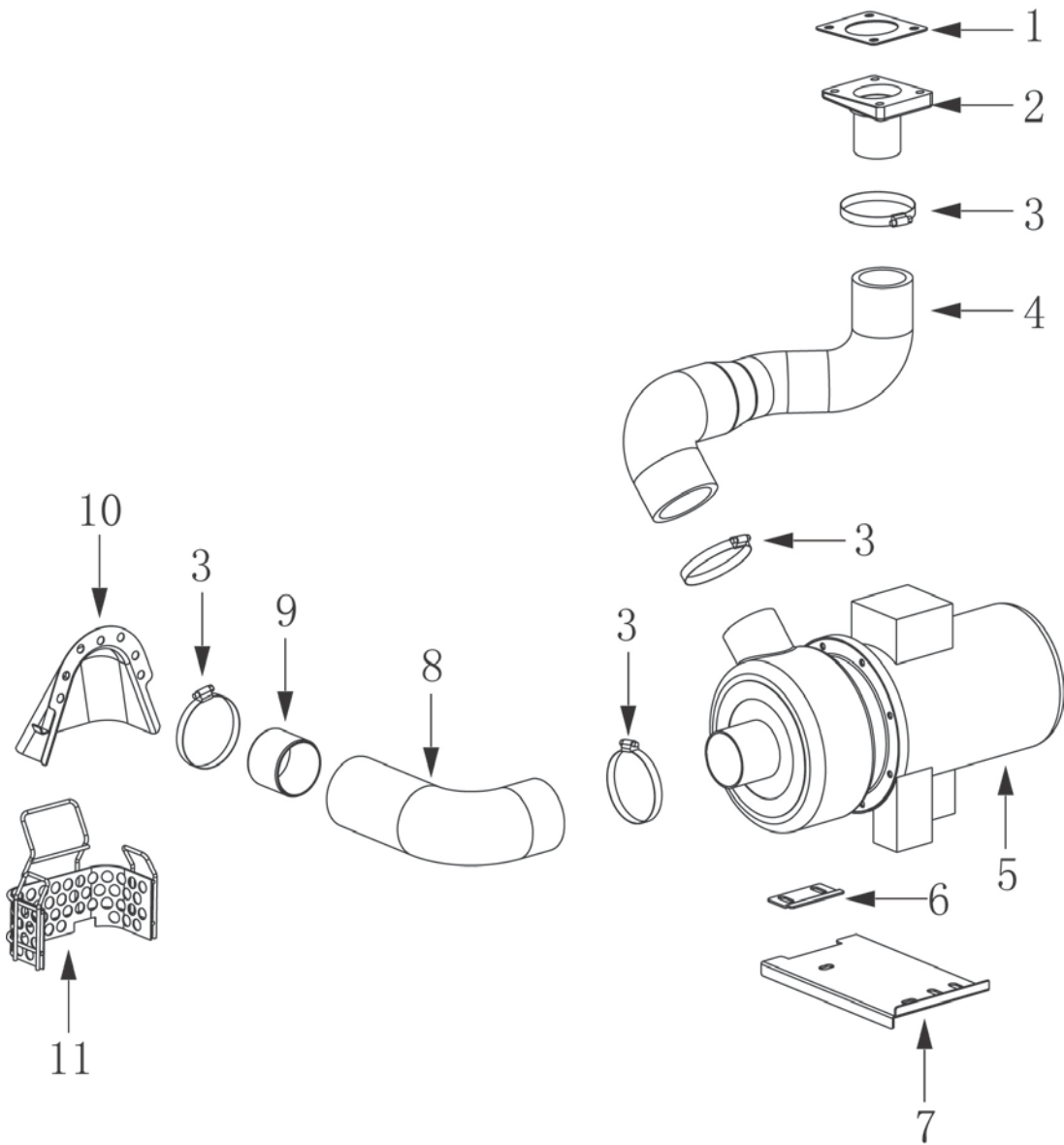

Fig. 13 清洗水泵
WASH MOTOR AND PUMP UNIT

C44BP SERIES DISHWASHER REPLACEMENT PARTS**清洗水泵****WASH MOTOR AND PUMP UNIT**

序号 No.	物料号 Part No	名称	Description	数量 Qty
1	270968	胶垫	Gasket- Washer Pipe	1
2	7154003	出水立管焊件	Tube	1
3	743315-1	喉箍 60-80	Clamp 60-80	4
4	7152090	泵出水管	Outlet Hose	1
5	7161212-4	清洗泵 50Hz	Wash Pump 50Hz	1
	7161212-5	清洗泵 60Hz	Wash Pump 60Hz	
6	7152092	固定板	Fixing Plate	1
7	7152093	泵支架	Bracke-Pump	1
8	7152091	泵进水管	Inlet Hose	1
9	7161245	节流芯	Throttle	1
10	742303	大靴罩焊件	Shroud	1
11	7152095	泵护网	Strainer-Pump	1

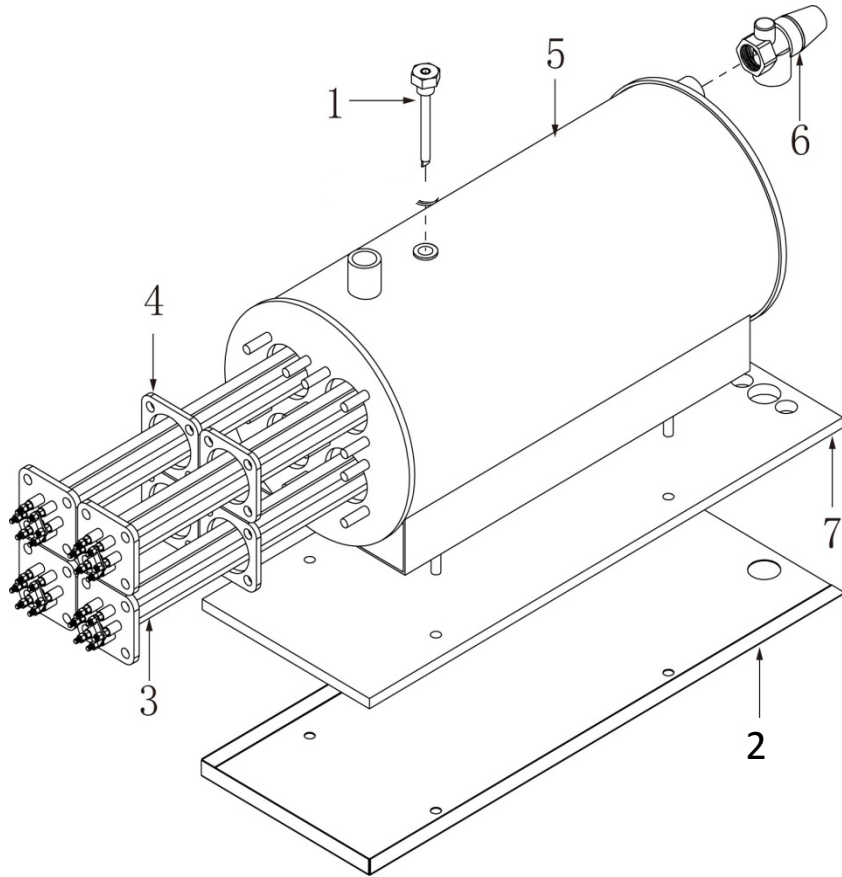

Fig. 14 加热器总成
BOOSTER ASSY

C44BP SERIES DISHWASHER REPLACEMENT PARTS

加热器总成 BOOSTER ASSY

序号 No.	物料号 Part No	名称	Description	数量 Qty
1	7152070	测温管焊件	Thermostat Sensor Tube	1
2	7152072	托水盘	Water Care	1
3	743800-5	电热管（星接）	Heating Element	4
4	743800-10	电热管密封垫	Gasket	4
5	7152071	Booster筒体焊件	Barrel	1
6	743856	安全总成	Safe Valve	1
7	7152073	隔热垫	Insulation	1

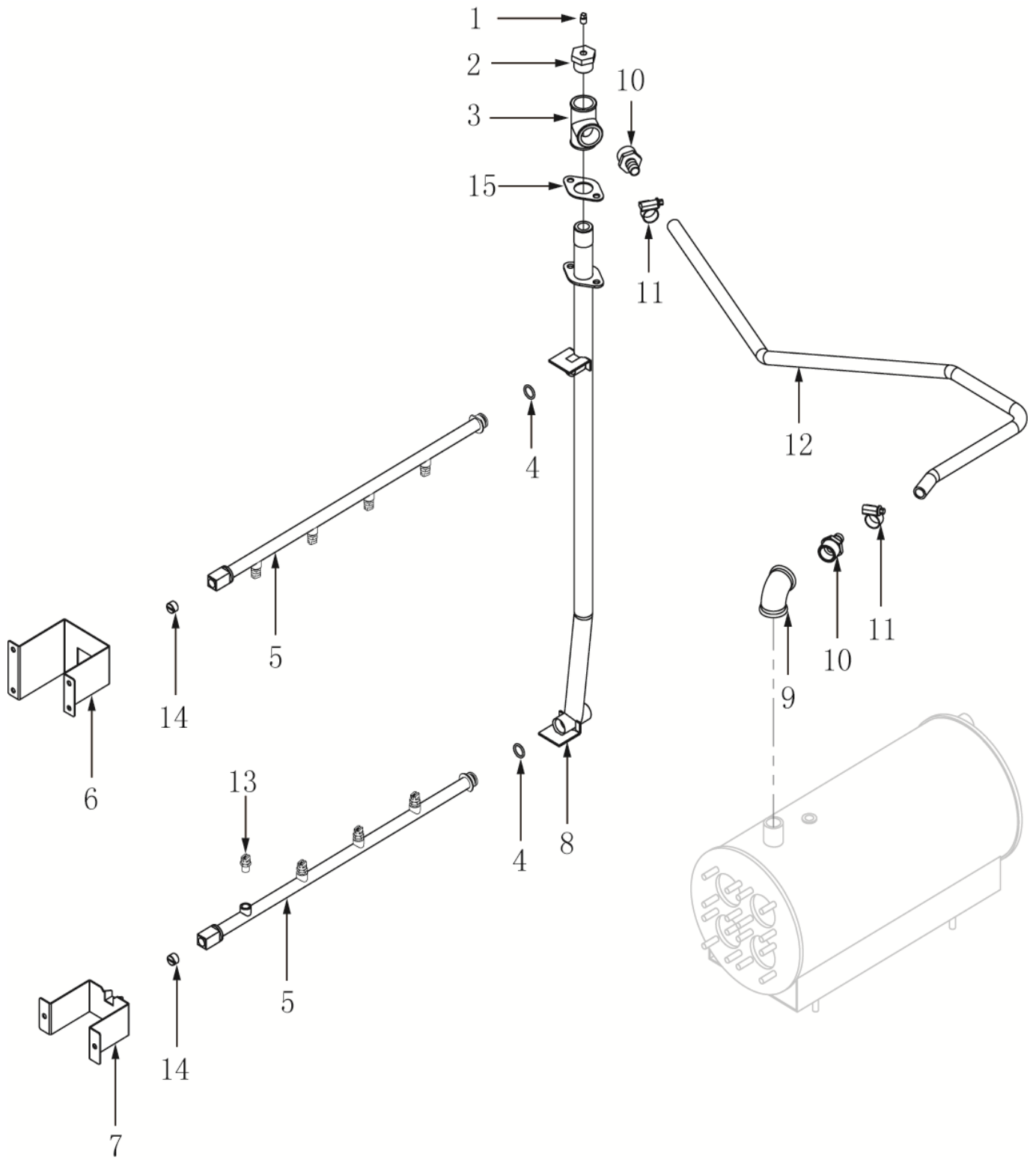

Fig. 15 喷淋管路总成 R-L
RINSE SYSTEM R-L

C44BP SERIES DISHWASHER REPLACEMENT PARTS

**喷淋管路总成R-L
RINSE SYSTEM R-L**

序号 No.	物料号 Part No	名称	Description	数量 Qty
1	FP-028-03	丝堵	Plug	1
2	FP-084-56	补芯	Bushing	1
3	7155111-4	三通	Tee	1
4	7155104-7	O型圈	O Ring	2
5	7152062	喷淋臂	Rinse Pipe	2
6	7152065	上喷淋臂支架 R-L	Holding Plate R-L	1
7	7152064	下喷淋臂支架	Holding Plate	1
8	7152061	喷淋立管合件 R-L	Rinse Pipe Assy	1
9	743289	弯头	Elbow	1
10	743284	胶管接头	Elbow	2
11	743315	喉箍 20	Hose Clamp 20	2
12	00-897293-01-1C	胶管	Hose	1
13	7152063	喷嘴	Nozzle	8
14	7155104-4	下喷淋臂堵头	Plug	2
15	276407	密封垫	Seal	1

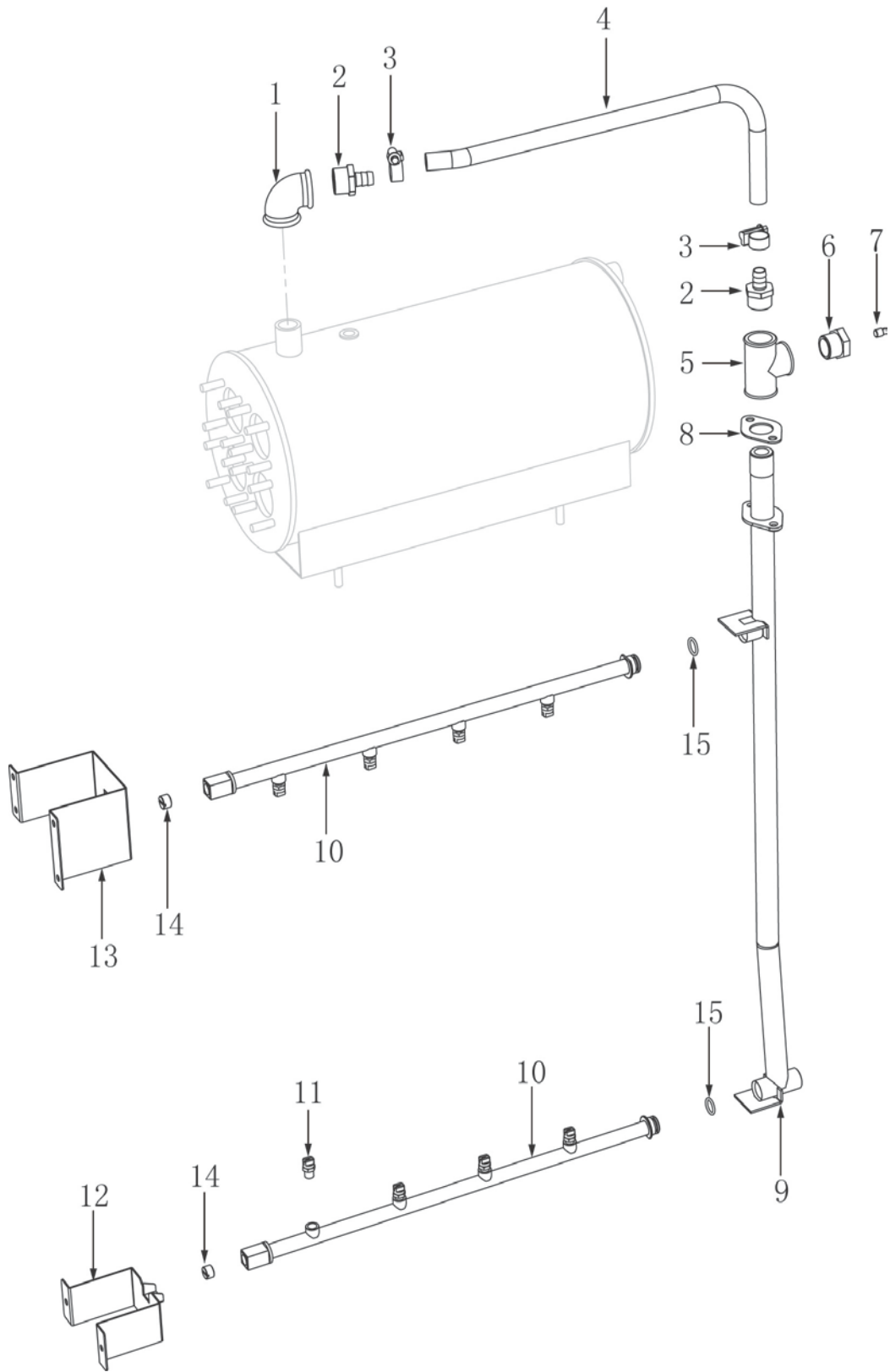

Fig. 16 喷淋管路总成 L-R
RINSE SYSTEM L-R

C44BP SERIES DISHWASHER REPLACEMENT PARTS**喷淋管路总成L-R
RINSE SYSTEM L-R**

序号 No.	物料号 Part No	名称	Description	数量 Qty
1	743289	弯头	Elbow	1
2	743284	胶管接头	Elbow	2
3	743315	喉箍 20	Hose Clamp 20	2
4	00-897293-01-2C	胶管 L-R	Hose L-R	1
5	7155111-4	三通	Tee	1
6	FP-084-56	补芯	Bushing	1
7	FP-028-03	丝堵	Plug	1
8	276407	密封垫	Seal	1
9	7152061L	喷淋立管合件 L-R	Rinse Pipe Assy L-R	1
10	7152062	喷淋臂	Rinse Pipe	2
11	7152063	喷嘴	Nozzle	8
12	7152064	下喷淋臂支架	Holding Plate	1
13	7152065L	上喷淋臂支架 L-R	Holding Plate L-R	1
14	7155104-4	下喷淋臂堵头	Plug	2
15	7155104-7	O型圈	O Ring	2

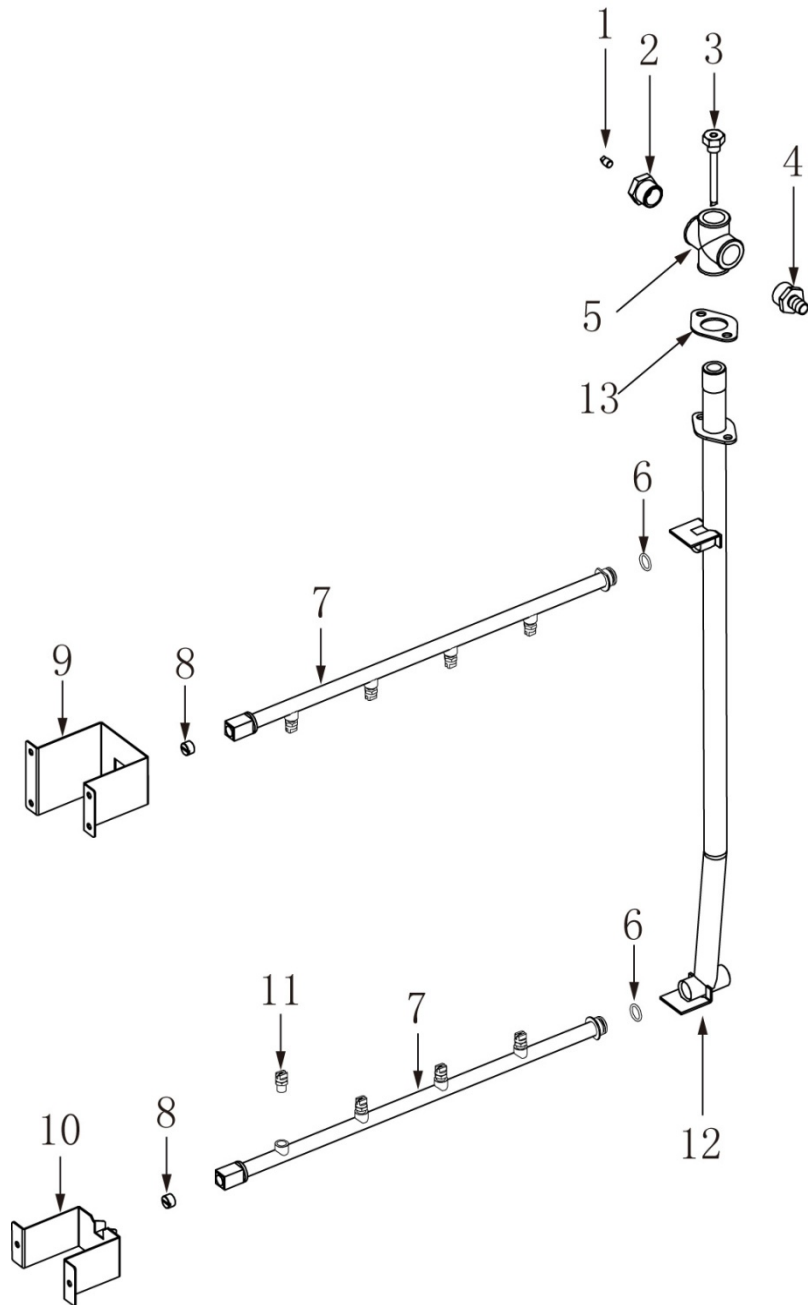

Fig.17 喷淋管路总成 (不带升温箱)
RINSE SYSTEM (WITHOUT BOOSTER)

喷淋管路总成(不带升温箱)
RINSE SYSTEM (WITHOUT BOOSTER)

序号 No.	物料号 Part No	名称	Description	数量 Qty
1	FP-028-03	丝堵	Plug	1
2	FP-084-56	补芯	Bushing	1
3	7159141-3	测温管焊件	Temperature Tube	1
4	743284	胶管接头	Elbow	1
5	7159140-1	四通	Cross Tee	1
6	7155104	O型圈	O Ring	2
7	7152062	喷淋臂	Rinse Pipe	2
8	7155104-4	下喷淋臂堵头	Plug	2
9	7152065	上喷淋臂支架 R-L	Holding Plate R-L	1
	7152065L	上喷淋臂支架 L-R	Holding Plate L-R	1
10	7152064	下喷淋臂支架	Holding Plate	1
11	7152063	喷嘴	Nozzle	8
12	7152061	喷淋立管合件R-L	Rinse Pipe Assy R-L	1
	7152061L	喷淋立管合件L-R	Rinse Pipe Assy L-R	1
13	276407	密封垫	Seal	1

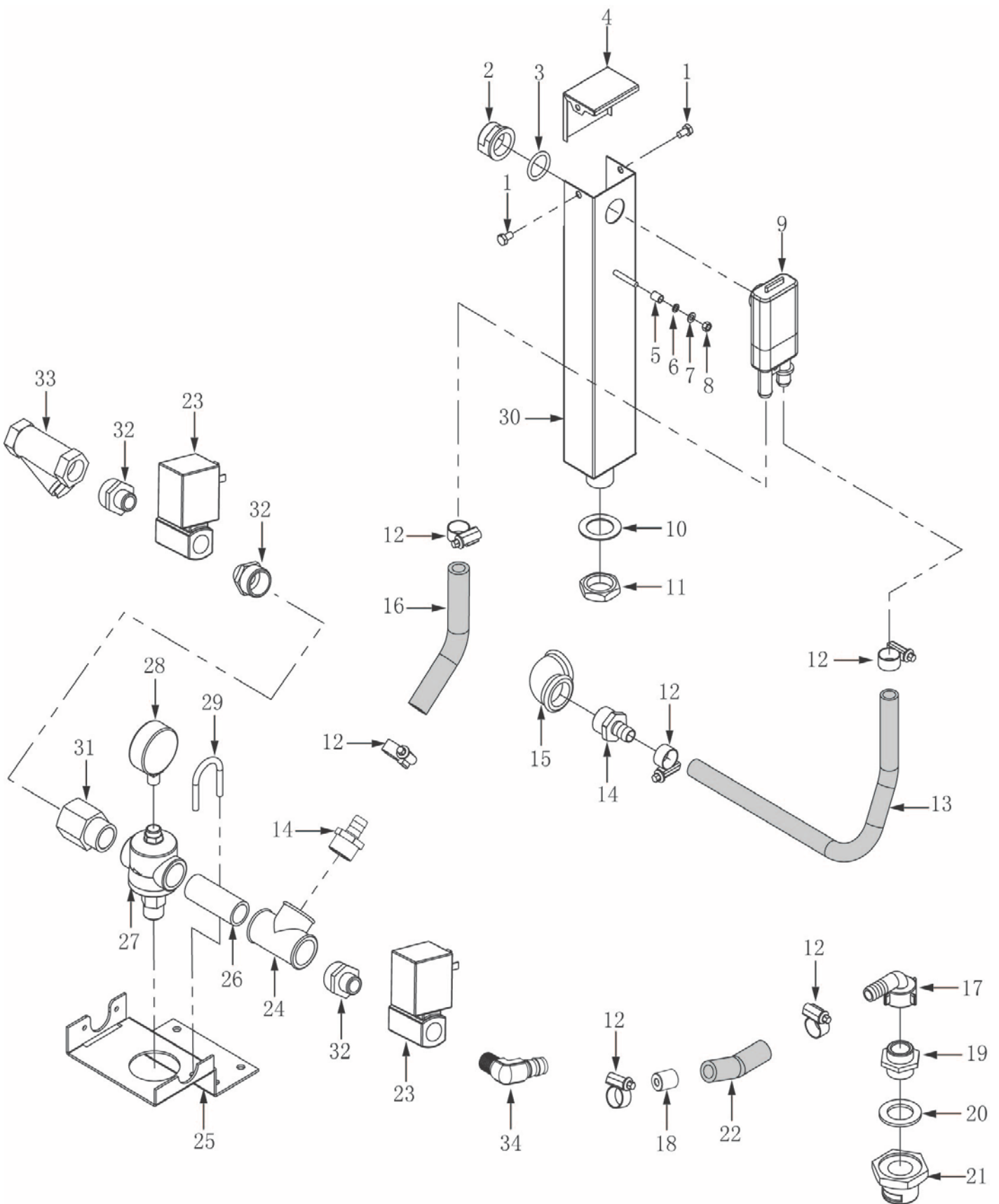

Fig. 18 进水管组件 (带升温箱)
 FILLING SYSTEM (WITH BOOSTER)

进水管组件 (带升温箱) FILLING SYSTEM (WITH BOOSTER)

序号 No.	物料号 Part No	名称	Description	数量 Qty
1	SCH-M5-10	螺母	Nut	2
2	324183	气隙盒螺母	Air Gap Nut	1
3	67500-10	O形圈	O Ring	1
4	7152016-4	盖板	Cover	1
5	743280	塑料套管	Tube	1
6	WL-M5	弹簧垫圈 M5	Lock Washer	1
7	WS-M5	平垫圈 M5	Washer	1
8	NS-M5	螺母 M5	Nut	1
9	00-775759-001	气隙盒	Air Gap	1
10	WS-13-45	垫圈	Washer	1
11	7155303-10	锁母	Lock Nut	1
12	743315	喉箍20	Hose Clamp	6
13	00-897293-01-6C	气隙盒出水胶管	Outlet Hose	1
14	743284	胶管接头	Union	2
15	743289	弯头	Elbow	1
16	00-897293-01-5C	气隙盒进水胶管	Inlet Hose	1
17	01-510685-001	铜弯头	Elbow	1
18	7159136-2	节流芯	Throttle	1
19	00-227931-000	联接头	Nipple	1
20	7159145-1	O型圈	O Ring	1
21	00-774670-001	挡水母	Cover Nut	1
22	00-897293-01-7C	胶管	Hose	1
23	7159061-1	进水电磁阀	Magnetic Valve	2
	7159061	进水电磁阀	Magnetic Valve	2
24	7155315-4	三通	Tee	1
25	7152068-1	进水管路支架	Holding Plate	1
26	7155111-2	短管	Tube	1
27	7155314-3	水路减压阀	Valve	1
28	328247	进水压力表	Pressure Gauge	1
29	743909	U形夹	U Clamp	1
30	7152016-3	方管焊件	Pipe Assy	1
31	7155122	内外丝	Nipple	1
32	7152507-001	铜外丝	Nipple	3
33	743287M	过滤器	Strainer	1
34	7152507-002	铜弯头	Elbow	1

C44BP SERIES DISHWASHER REPLACEMENT PARTS

进水管组件 (不带升温箱)
FILLING SYSTEM (WITHOUT BOOSTER)

序号 No.	物料号 Part No	名称	Description	数量 Qty
1	743315	喉箍20	Hose Clamp	4
2	00-897293-01-3C	进水胶管 (无升温箱) R-L	Inlet Hose R-L	1
	00-897293-01-4C	进水胶管 (无升温箱) L-R	Inlet Hose L-R	1
3	01-510685-001	铜弯头	Elbow	2
4	7159061-1	电磁阀	Magnetic Valve	2
	7159061	电磁阀	Magnetic Valve	2
5	7155314-3	水路减压阀	Valve	1
6	743909	U形夹	U Clamp	1
7	7155111-2	短管	Tube	1
8	7155315-4	三通	Tee	1
9	743286	外丝	Nipple	1
10	7152068-1	进水管路支架	Holding Plate	1
11	00-897293-01-7C	胶管	Hose	1
12	7159136-2	节流芯	Throttle	1
13	00-227931-000	联接头	Nipple	1
14	7159145-1	O型圈	O Ring	1
15	00-774670-001	挡水母	Cover Nut	1
16	328247	进水压力表	Pressure Gauge	1
17	7155122	内外丝	Nipple	1
18	7152507-001	铜外丝	Nipple	4
19	743287M	过滤器	Strainer	1
20	7152507-002	铜弯头	Elbow	1