

**HOBART**

CATALOG OF  
REPLACEMENT PARTS

**AM2 ATTACHMENT BROCHURE**

**AM2 DISHWASHERS**

Series number from

210010 .....

HOBART FOOD EQUIPMENT CO., LTD

version 1 (06/2001)

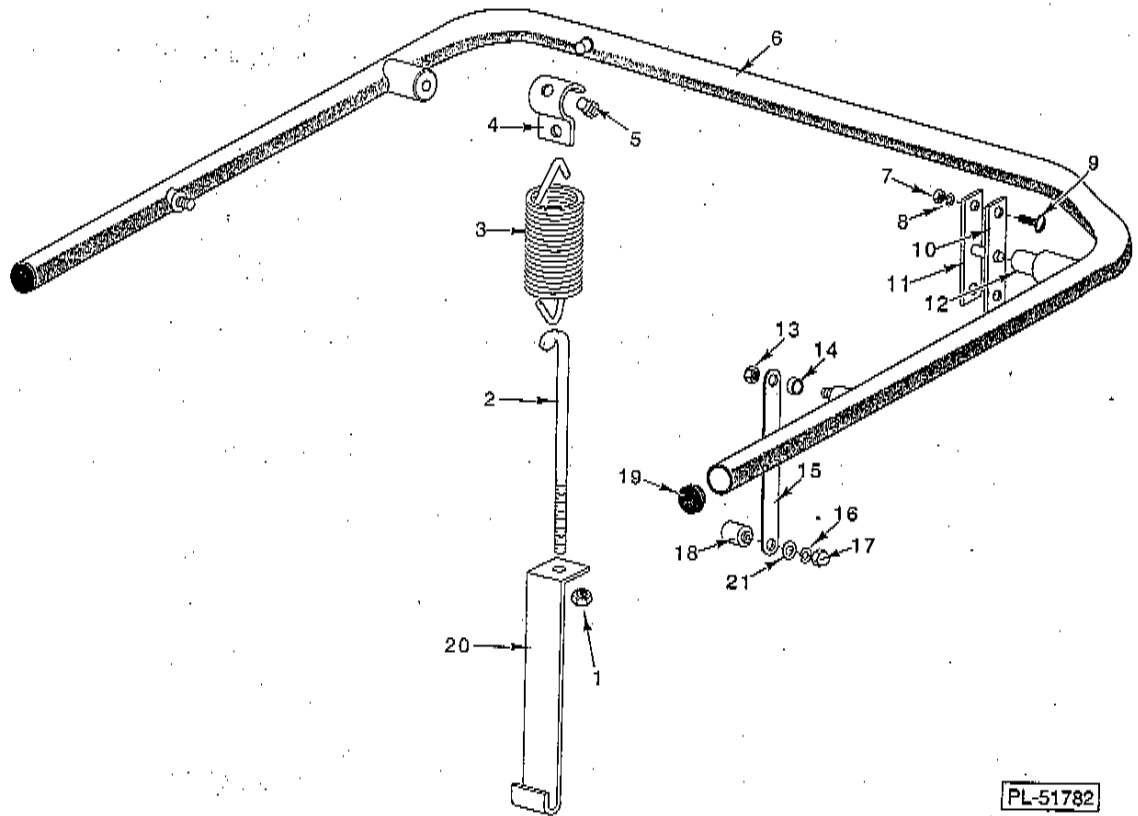

PL-51782

DOOR LIFT

ILLUS. NO.	PART NO.	NAME OF PART	AMT.
1	NS-15-11	Full Nut 1/8-18 Hex	2
2	186334-2	Hook - Spring	1
3	119079-2	Spring - Counterbalance	1
4	79008	Hanger - Spring	1
5	119055	Button - Bearing	1
6	474080-1	Door Lift Assy.	2
7	NS-15-11	Full Nut 1/8-18 Hex	1
8	WL-6-23	Lockwasher 1/8 Medium SST	4
9	SC-53-16	Mach. Screw 1/8-18 x 1/4 Truss HD.	4
10	119053	Gasket - Door Lift	4
11	119017	Bearing Bracket & Pin Assy.	2
12	119104	Bushing - Door Lift Pin	2
13	NS-32-35	Stop Nut 1/8-18 "Flexloc"	2
14	74088	Spacer - Door Link	2
15	119011	Link - Door	2
16	WL-6-23	Lockwasher 1/8 Medium SST	2
17	NS-25-9	Nut 1/8-18 Crown	2
18	119046	Pin - Door Lift	2
19	119076	Plug - Handle	2
20	185044	Bracket - Spring	2
21	WS-5-32	Washer	1

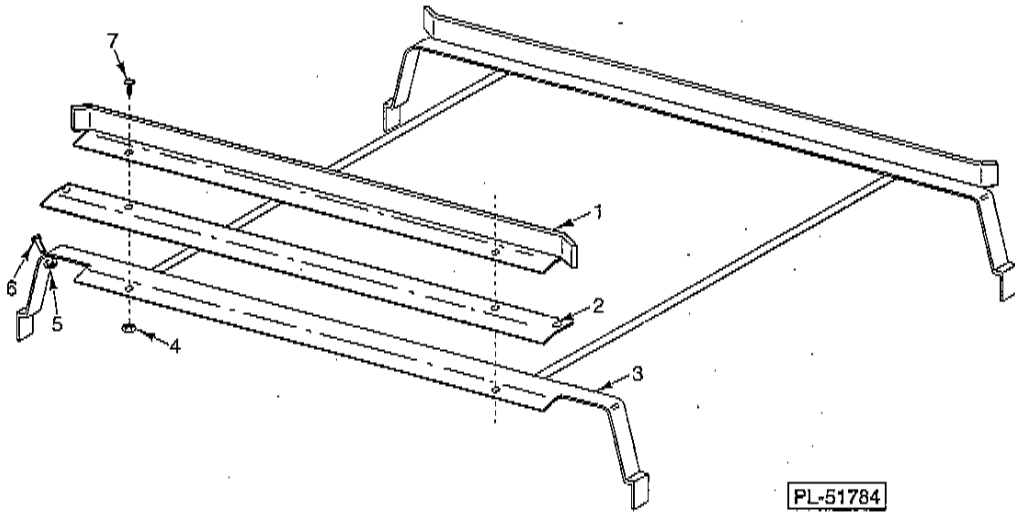

TRACKS

ILLUS.	PART NO.	NAME OF PART	AMT.
1	185050	Side - Rack Track .....	1
2	185053	Guard - Door Splash .....	1
3	435036	Track Weldment .....	1
4	NS-31-15	Stop Nut - Special 10-24 Hex (SST) .....	2
5	NS-31-15	Stop Nut - Special 10-24 Hex (SST) .....	2
6	SC-53-2	Mach. Screw 10-24 x 1/2 Truss Hd. SST .....	2
7	SC-53-2	Mach. Screw 10-24 x 1/2 Truss Hd. SST .....	2

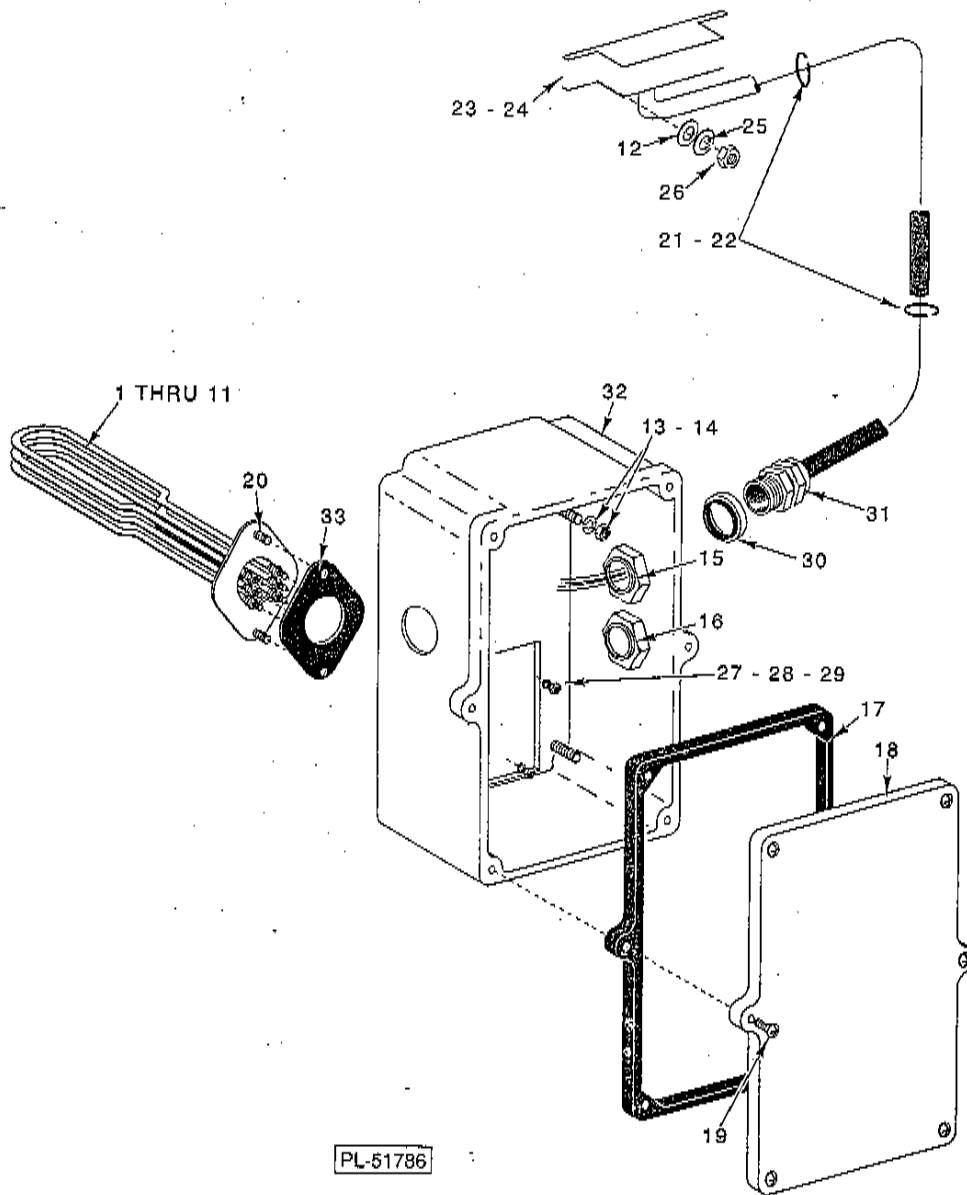

PL-51786

**ELECTRIC HEAT BOX AND ELEMENT**

## ELECTRIC HEAT BOX AND ELEMENT

ILLUS. PL-51786	PART NO.	NAME OF PART	AMT.
1	473761-1	Heater - Sump (100/1)(2000 Watts) .....	1
2	473761-2	Heater - Sump (200-208/3)(2000 Watts) .....	1
3	473761-3	Heater - Sump (220-240/3)(2000 Watts) .....	1
4	473761-12	Heater - Sump (380-415/3)(500 Watts) .....	1
5	473761-5	Heater - Sump (220-240/1)(2000 Watts) .....	1
6	473761-6	Heater - Sump (380-415/3)(2000 Watts) .....	1
7	473761-7	Heater - Sump (100/1)(500 Watts) .....	1
8	473761-8	Heater - Sump (200-208/3)(500 Watts) .....	1
9	473761-9	Heater - Sump (220-240/3)(500 Watts) .....	1
10	473761-10	Heater - Sump (200-208/1)(500 Watts) .....	1
11	473761-11	Heater - Sump (220-240/1)(500 Watts) .....	1
12	WS-23-21	Washer .....	2
13	WL-6-17	Lockwasher 1/4 Medium .....	4
14	NS-15-1	Full Nut 1/4-20 Hex .....	4
15	FE-24-88	Locknut 1/2 .....	1
16	FE-24-88	Locknut 1/2 .....	1
17	112005	Gasket (Lid) .....	1
18	289146-1	Lid & Gasket Assy. (Incls item 17) .....	1
19	SD-12-20	Self-Tapping Screw 8-32 x 1/2 Phil. Truss Hd., Type T .....	6
20	SC-41-12	Cap Screw 3/16-18 x 3/8 Hex Hd. ....	2
21	122577-2	Wire Tie .....	2
22	NS-47-94	Nut-Lock Special 3/16 .....	2
23	474098-2	Door Interlock Assy. ....	1
24	474098-3	Switch - Interlock (W/ Electric Booster) .....	1
25	WL-6-42	Lockwasher 6 Medium .....	2
26	NS-11-7	Mach. Nut 6-32 Hex .....	2
27	WS-17-8	Washer .....	2
28	WL-6-23	Lockwasher 5/16 Medium SST .....	2
29	NS-15-11	Full Nut 5/16-18 Hex .....	2
30	FE-8-10	1/2 Gasket Assy. ....	2
31	FE-22-84	Connector - Strain Relief .....	2
32	473976	Box - Electric Sump Heat .....	1
33	293598	Gasket - Heater Mounting .....	1

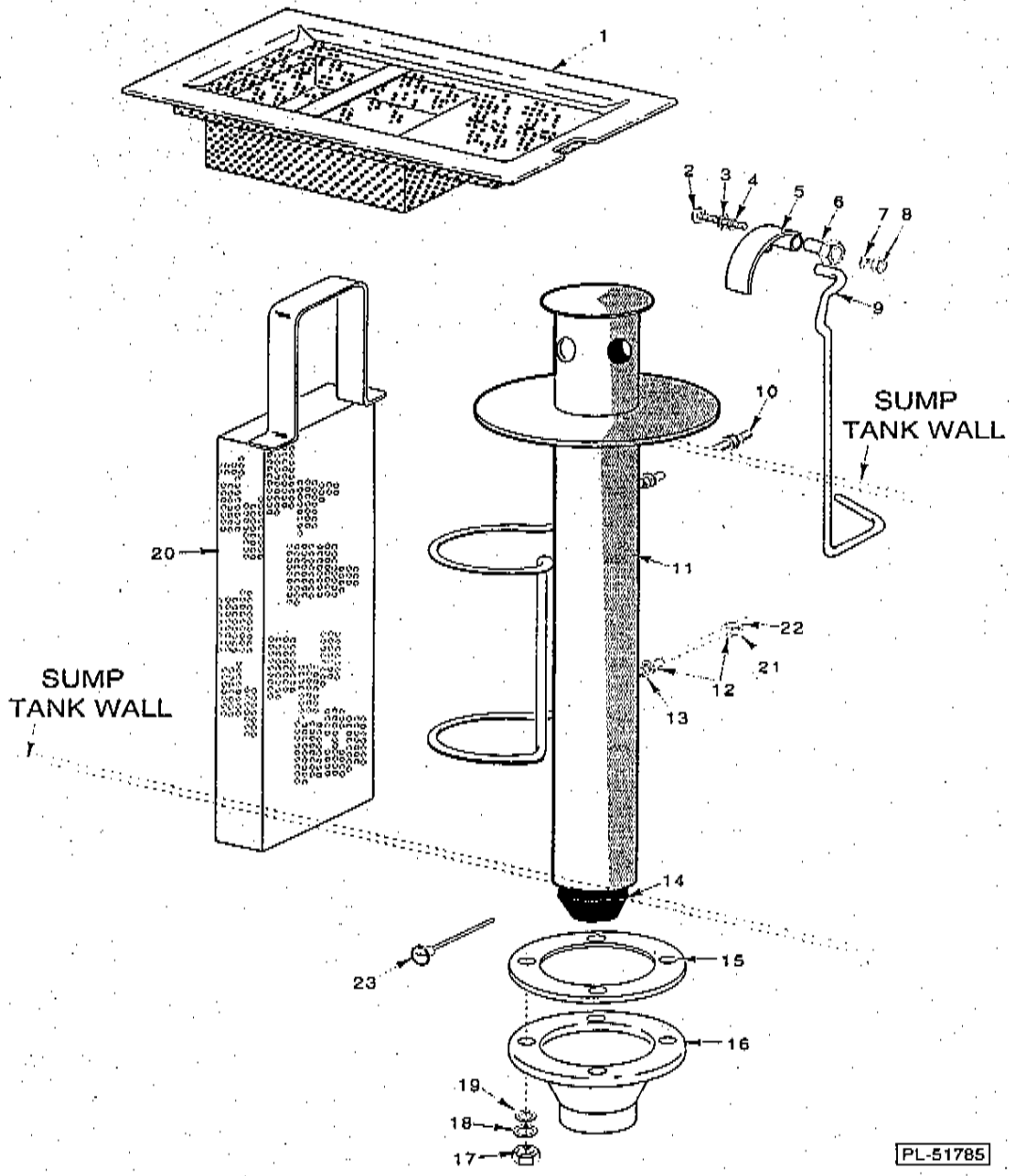

STRAINERS AND DRAIN UNIT

## STRAINERS AND DRAIN UNIT

ILLUS	PART NO.	NAME OF PART	AMT.
1	742077	Strainer Assy	1
2	SCT-M6-35	Scrow (M6x35)	1
3	WL-M6	Lockwasher 10 Medium	1
4	WS-M6	Washer	1
5	742095	Drain Lever Assy	1
6	7111003	Axle - Drain lever	1
7	ML-M6	Lockwasher 10 Medium	1
8	NS-M6	Full Nut 1/4 Medium	1
9	119119	Rod - Overflow Lift	1
10	473982	Retainer-Tube Overflow	1
11	742082	Overflow Tube Assy	1
12	WS-17-6	Washer	4
13	NS-18-1	Jam Nut 1/4 -20 Hex	2
14	474689	Stopper - Drain	1
15	473983	Gasket - Drain	1
16	473759	Sump - Drain	1
17	NS-15-1	Full Nut 1/4 -20 Hex	4
18	WL-6-17	Lockwasher 10 Medium	4
19	WS-17-6	Washer	4
20	742087	Intake Pump Strainer Assy	1
21	WL-6-17	Lockwasher 1/4 Medium	2
22	NS-18-1	Jam Nut 1/4 - 20 Hex	2
23	473988	Thermometer	1

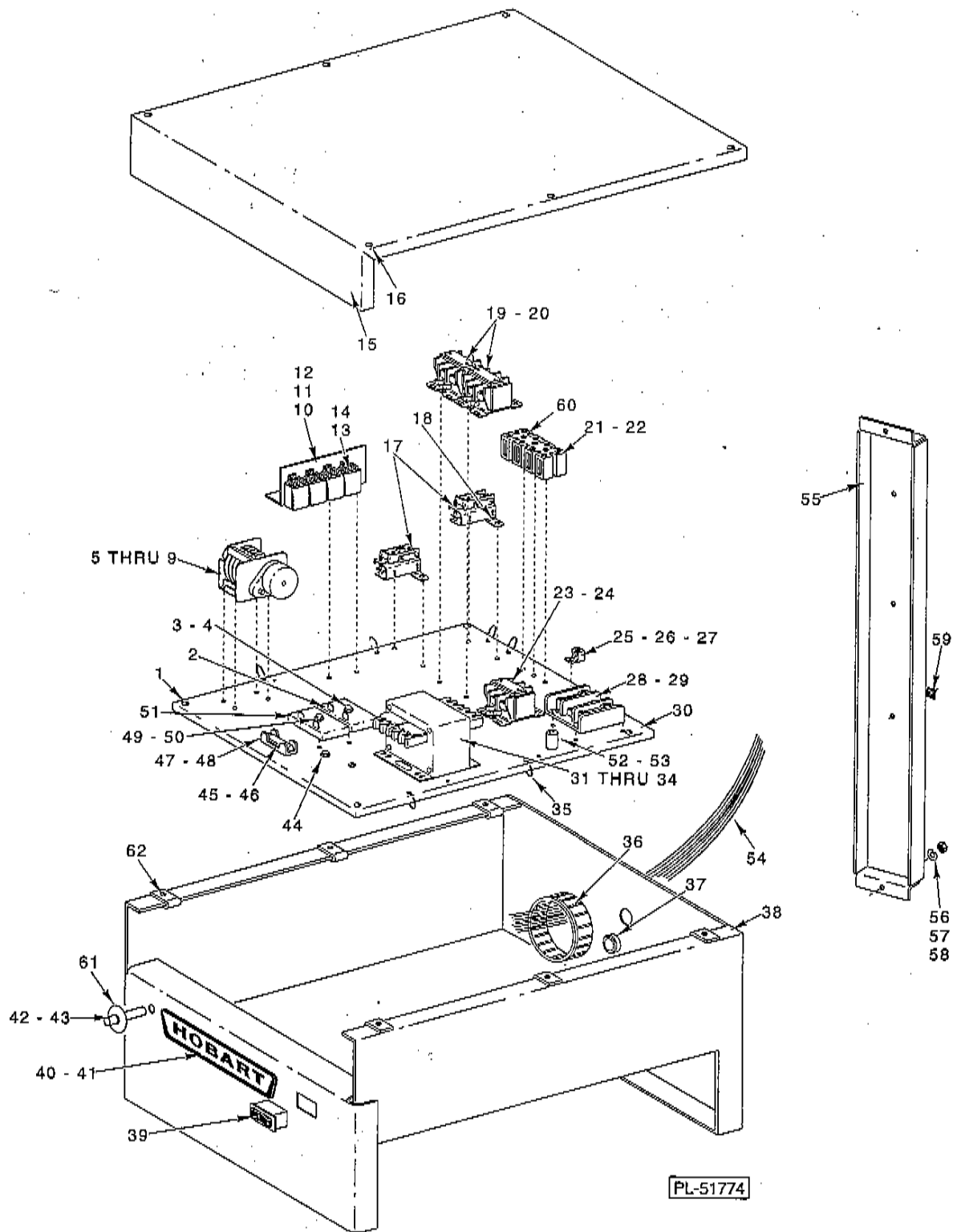

CONTROL BOX ASSY.



## CONTROL BOX ASSY.

ILLUS. PL-51774	PART NO.	NAME OF PART	AMT.
1	SC-83-5	Mach. Screw 10-24 x 3/4 Truss Hd, Slotted	4
2	87714-31-2	Relay Time Delay (5 Sec.)	1
3	SD-36-13	Self-Tapping Screw 1/4-20 x 1 1/4 Slotted Hex Washer Hd., Type T	1
4	WL-7-15	Lockwasher 1/4 External Shakeproof	1
5	474071-1	Cam Timer Assy. (120V., 60HZ., 60 Sec.)	1
6	474071-2	Cam Timer Assy. (120V., 50HZ., 60 Sec.)	1
7	474071-3	Cam Timer Assy. (120V., 60HZ., 90 Sec.)	1
8	474071-4	Cam Timer Assy. (120V., 50HZ., 90 Sec.)	1
9	SD-8-18	Self-Tapping Screw 8-18 x 3/8 Phil. Bind Hd., Type B	4
10	437103	Bracket - Relay Mtg.	1
11	SD-8-25	Self-Tapping Screw 10 x 3/8 Phil Bind Hd., Type B	2
12	WL-14-7	Lockwasher 10 External Shakeproof(SST)	2
13	87714-20-2	Relay (3 P.D.T.)(10A., 120 V.A.C.)	4
14	SD-19-29	Self-Tapping Screw 6-20 x 1/2 Phil Pan Hd., Type B	8
15	473973	Lid - Box Control	1
16	SC-53-5	Mach. Screw 10-24 x 3/4 Truss Hd, Slotted	6
17	294681-20-2	Thermostat - Tank Heat	2
18	SD-8-25	Self-Tapping Screw 10 x 3/8 Phil Bind Hd., Type B	4
19	87713-40-2	Contacto - 30 Amp 3 Pole	2
20	SD-8-25	Self-Tapping Screw 10 x 3/8 Phil Bind Hd., Type B	4
21	294325-13-2	Block - Terminal (Over 250 Volts)	1
22	294325-13-4	Block - Terminal (Under 250 Volts)	1
23	87713-41-2	Contacto 40 Amp 3 Pole	1
24	SD-8-25	Self-Tapping Screw 10 x 3/8 Phil Bind Hd., Type B	2
25	118544-2	Lug - Grounding	1
26	SD-35-77	Self-Tapping Screw 1/4-20 x 3/8 Phil.Pan Hd., Type TT	1
27	WL-7-15	Lockwasher 1/4 External Shakeproof	1
28	119031	Terminal Block	1
29	SD-8-1	Self-Tapping Screw 10 x 3/8 Rd. Hd., Type B	4
30	474083	Plate - Base	1
31	294500-28	Transformer (50VA, 3PH., W/Elec. Booster; Hi-Volt W/O Booster)	1
32	294500-24-2	Transformer (300VA, 50/60Hz.)(High Voltage)	1
33	SD-8-25	Self-Tapping Screw 10 x 3/8 Phil Bind Hd., Type B	4
34	WL-14-7	Lockwasher 10 External Shakeproof(SST)	4
35	113703	Cable Tie	6
36	FE-24-13	Bushing - Electrical 2 1/2 3/4 I.D.	1
37	274947	Grommet	1
38	473969	Control Box Weldment	1
39	87711-254-2	Switch - Rocker (DPDT)	1
40	280224	Nameplate - Hobart	1
41	206177	Clip - Nameplate	2
42	294700-4-6	Light - Pilot	1
43	TW-1-65	Terminal	2
44	SD-8-25	Self-Tapping Screw 10 x 3/8 Phil Bind Hd., Type B	1
45	FE-22-28	Fuse 250V 1/2 Amp	1
46	FE-21-19	Fuse 3.2 Amps	1
47	294436-3	Block - Fuse	1
48	SD-19-29	Self-Tapping Screw 6-20 x 1/2 Phil Pan Hd., Type B	1
49	SD-36-13	Self-Tapping Screw 1/4-20 x 1 1/4 Slotted Hex Washer Hd., Type T	1
50	WL-7-15	Lockwasher 1/4 External Shakeproof	1
51	87714-31-3	Relay-Time Delay (15 Sec.)	1
52	473936-1	Capacitor - Motor Starter (22 Micro)(100-120/1)	1
53	473936-2	Capacitor - Motor Starter (5 Micro) (200-240/1)	1
54	473526-1	Harness - Base Plate	1
55	473968	Chase - Wireway	1
56	WS-22-1	Washer	4
57	WL-6-7	Lockwasher 10 Medium	4
58	NS-11-18	Mach. Nut 10-24 Hex	1
59	NS-47-94	Nut-Lock Special 3/16	1
60	SD-19-29	Self-Tapping Screw 6-20 x 1/2 Phil Pan Hd., Type B	2
61	473705	Label - Cycle Light	1
62	74348	Speed Nut 10 - 24	6

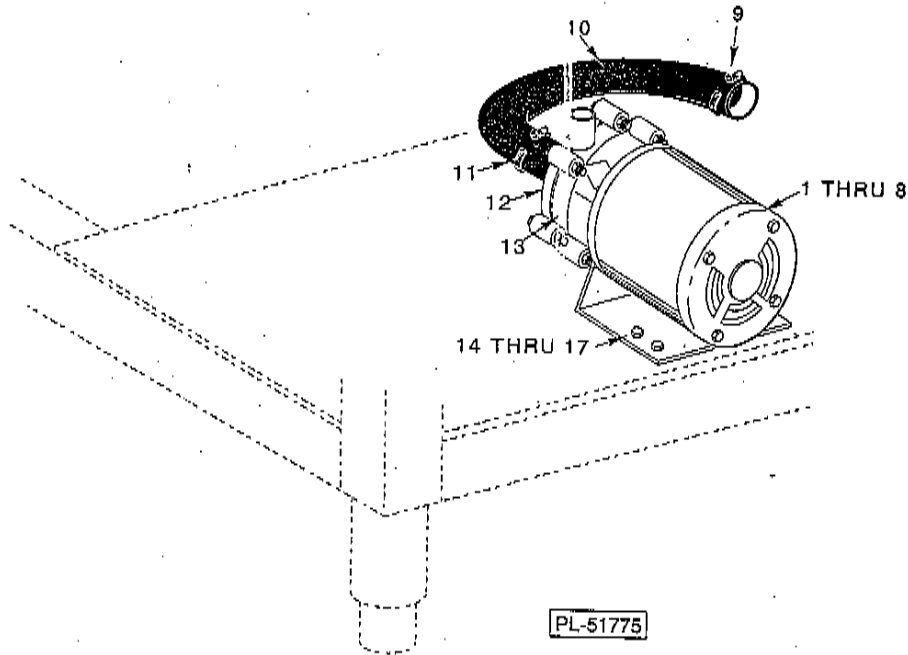

**PUMP & MOTOR**

ILLUS. PL-51775	PART NO.	NAME OF PART	AMT.
1	473661-1	Pump / Motor Assy. (380/61/3) .....	1
2	329240-10	Motor Assy. (380/60/3) .....	1
3	473661-2	Pump / Motor Assy. (220-230/460/60/3) (190/380-415/50/3) .....	1
4	329240-11	Motor Assy. (220-230/460/50/3) (190/380-415/50/3) .....	1
5	473661-3	Pump / Motor Assy. (200/60/50/3) .....	1
6	329240-12	Motor Assy. (200/60/50/3) .....	1
7	474089-1	Pump / Motor Assy. (115/30/50/60/1) .....	1
8	329240-8	Motor Assy. (115/230/50/60/1) .....	1
9	538412	Clamp - Hose # 24 .....	1
10	473974	Hose - Wash Pump .....	1
11	538412	Clamp - Hose # 24 .....	1
12	329240-2	Support - Head (Pump - Rear) .....	1
13	329240-3	Casing (Pump Front) .....	1
14	SC-41-12	Cap Screw 3/16-18 x 7/8 Hex Hd. ....	1
15	NS-15-11	Full Nut 3/16-18 Hex .....	4
16	WL-6-23	Lockwasher 3/16-Medium SST .....	4
17	WS-17-8	Washer .....	4
	329240-4	Shaft Seal Kit (Incls. Seal, O Ring & Shims)(Not Shown) .....	8
	329240-9	Impeller Kit (1Ph)(Incls. mpeller, Casting, O Rings & Hwd.)(Not Shown) .....	1
	329240-13	Impeller Kit (3Ph)(Incls. mpeller, casting, o Rings & Hwd.)(Not Shown) .....	1
	329240-6	Plug Kit (Incls. Nylon Plug & O Ring)(Not Shown) .....	1
	329240-7	Shim Kit (Not Shown) .....	1

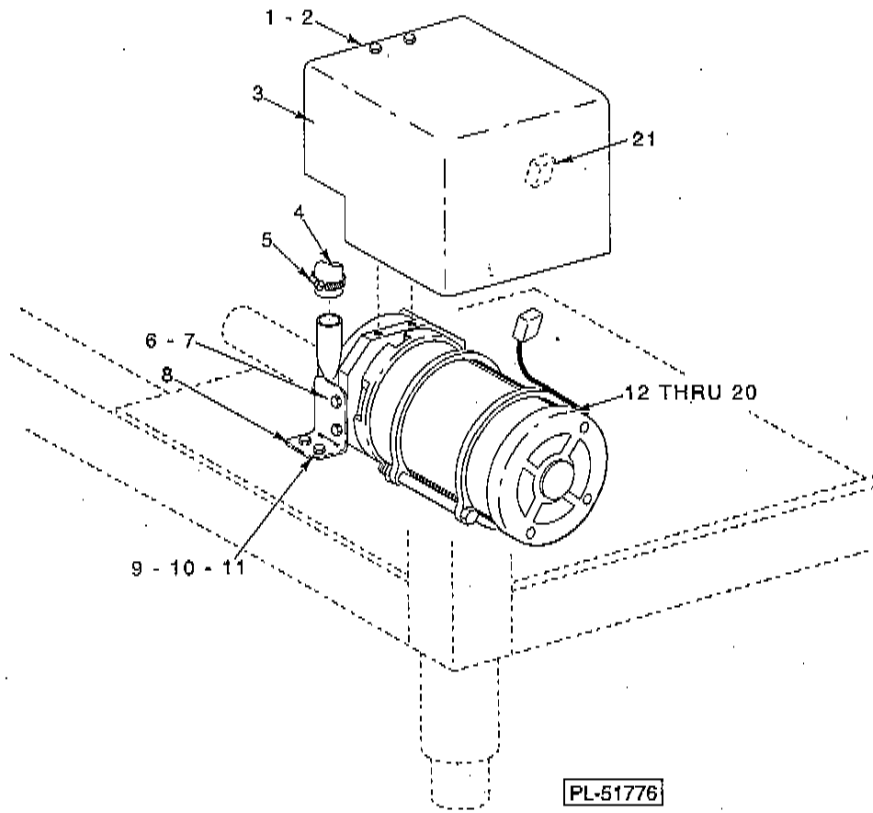

PL-51776

RINSE PUMP

ILLUS. NO.	PART NO.	NAME OF PART	AMT.
1	SC-118-47	Cap Screw M6 x 1.0 x 16 MM Hex Hd.	2
2	WL-6-17	Lockwasher 1/4 Medium	2
3	473986	Cover - Pump	1
4	545674	Hose (9") (Cut to Length)	AR
5	521687	Clamp - Hose	2
6	SC-118-47	Cap Screw M6 x 1.0 x 16 MM Hex Hd.	2
7	WL-6-17	Lockwasher 1/4 Medium	2
8	473985	Bracket - Rinse Pump	1
9	SC-41-10	Cap Screw 5/16-18 x 5/8 Hex Hd.	1
10	NS-15-11	Full Nut 5/16-18 Hex	1
11	WL-6-23	Lockwasher 5/16 Medium SST	1
12	474070-1	Pump - Rinse (200-240/50/1)	1
13	474070-2	Pump - Rinse (220/60/1)	1
14	474070-3	Pump - Rinse (100-120/60/1)	1
15	474070-4	Pump - Rinse (100-120/50/1)	1
16	474070-5	Pump - Rinse (380-415/50/3)	1
17	474070-6	Pump - Rinse (380/60/3)	1
18	474070-7	Pump - Rinse (200/50/3)	1
19	474070-8	Pump - Rinse (200/60/3)	1
20	474070-9	Pump - Rinse (220-240/60/3)	1
21	122895	Connector	1

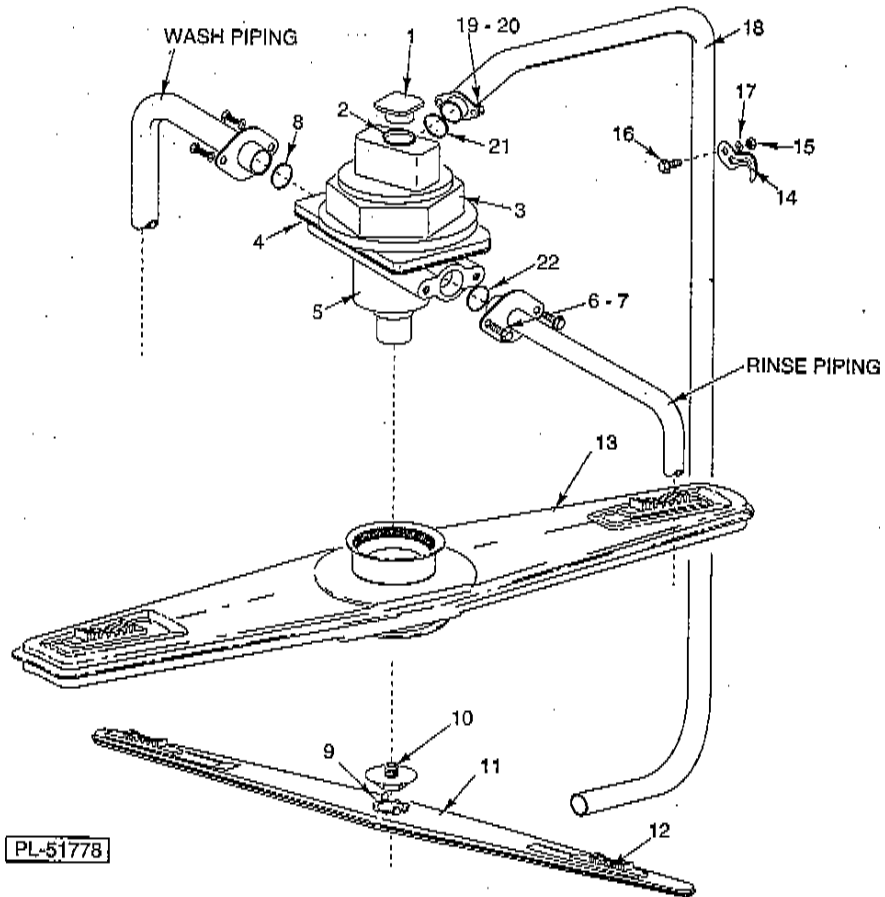

UPPER WASH & RINSE ARMS

## UPPER WASH &amp; RINSE ARMS

ILLUS. PL-51778	PART NO.	NAME OF PART	AMT.
1	473690	Plug - Manifold .....	1
2	67500-10	"O" Ring .....	1
3	473460	Nut - Manifold .....	1
4	473984	Gasket - Manifold .....	1
5	474260	Shaft/Mannifold, Upper Assy. ....	1
6	SC-41-50	Cap Screw 1/4-20 x 1/2 Hex Hd. ....	4
7	WL-6-17	Lockwasher 1/4 Medium .....	4
8	67500-10	"O" Ring .....	1
9	474225	Ring - Locking .....	1
10	473637	Bearing Assy.-Rinse Arm(Incls. Balls, Inner & Outer Races, Nut & Retaining Ring) .....	1
11	473688	Arm - Rinse .....	1
12	473760	Plug-Clean-Out (Sliding)(2 per Arm) .....	4
13	474099	Wash Arm Assy.(Incls. Hub, Balls, Retainer & Screws) .....	1
14	FE-25-17	Clamp - Electrical 3/4 TS .....	1
15	NS-15-11	Full Nut 3/8-18 Hex .....	1
16	SC-53-16	Mach. Screw 3/8-18 x 3/8 Truss HD. ....	1
17	WL-6-23	Lockwasher 3/8 Medium SST .....	1
18	473966	Outside Rinse Piping Assy. ....	1
19	SC-41-50	Cap Screw 1/4-20 x 1/2 Hex Hd. ....	2
20	WL-6-17	Lockwasher 1/4 Medium .....	2
21	67500-10	"O" Ring .....	1
22	67500-6	"O" Ring .....	1

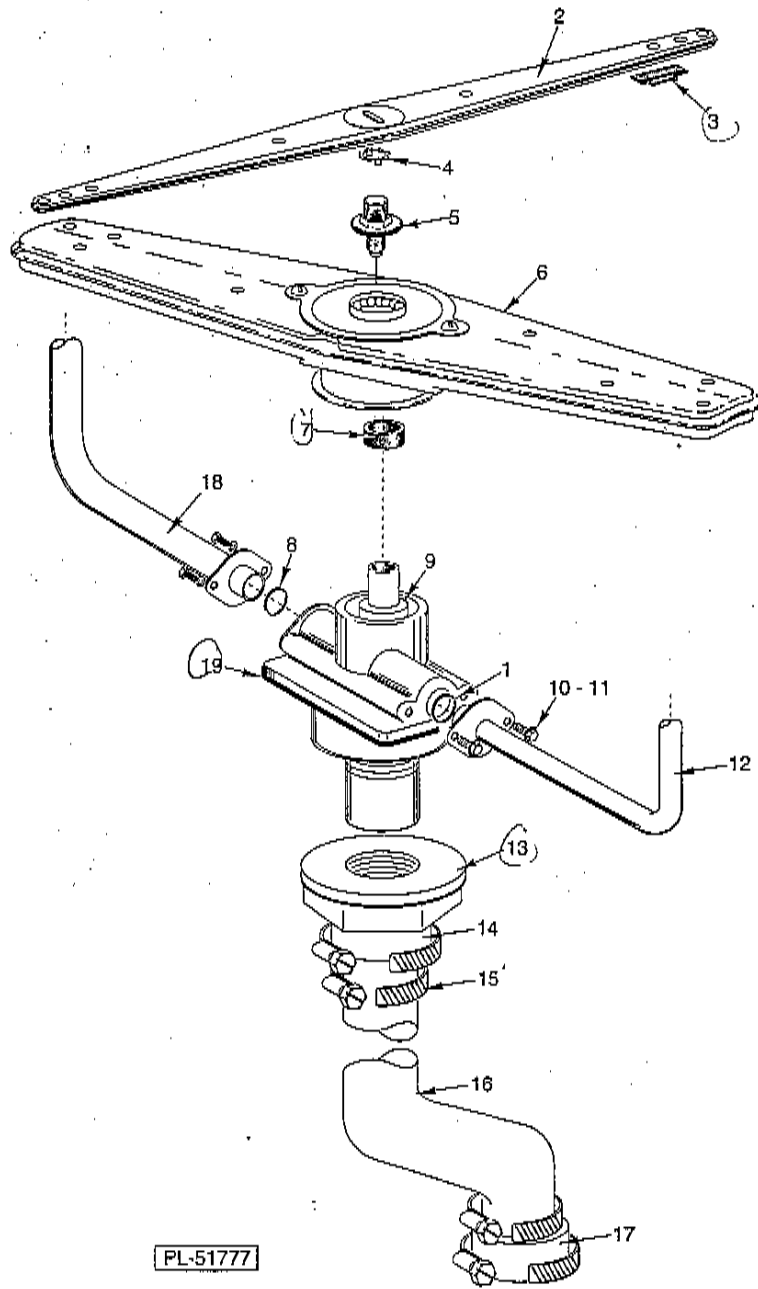

LOWER WASH & RINSE ARMS

LOWER WASH & RINSE ARMS

ILLUS. PL-51777	PART NO.	NAME OF PART	AMT.
1	67500-6	"O" Ring .....	1
2	473688	Arm - Rinse .....	1
3	473760	Plug-Clean-Out (Sliding)(2 per Arm) ..... <i>474674</i>	4
4	474225	Ring - Locking .....	1
5	473637	Bearing Assy.-Rinse Arm(Incls. Balls, Inner & Outer Races, Nut & Retaining Ring) .....	1
6	474099	Wash Arm Assy.(Incls. Hub, Balls, Retainer & Screws) .....	1
7	286944	Spacer .....	1
8	67500-10	"O" Ring .....	1
9	474261	Shaft/Manifold, Lower Assy. .... <i>change to 474678</i>	1
10	SC-41-50	Cap Screw 1/4-20 x 1/2 Hex Hd. ....	4
11	WL-6-17	Lockwasher 1/4 Medium .....	4
12	473984	Piping - Rinse .....	1
13	473460	Nut - Manifold .....	1
14	545655	Hose (Cut to 2 3/4" Length) .....	AR
15	538412	Clamp - Hose # 24 .....	4
16	474218	Tube .....	1
17	545655	Hose (Cut to 2 3/4" Length) .....	AR
18	473961	Piping - Wash .....	1
19	473984	Gasket - Manifold .....	1

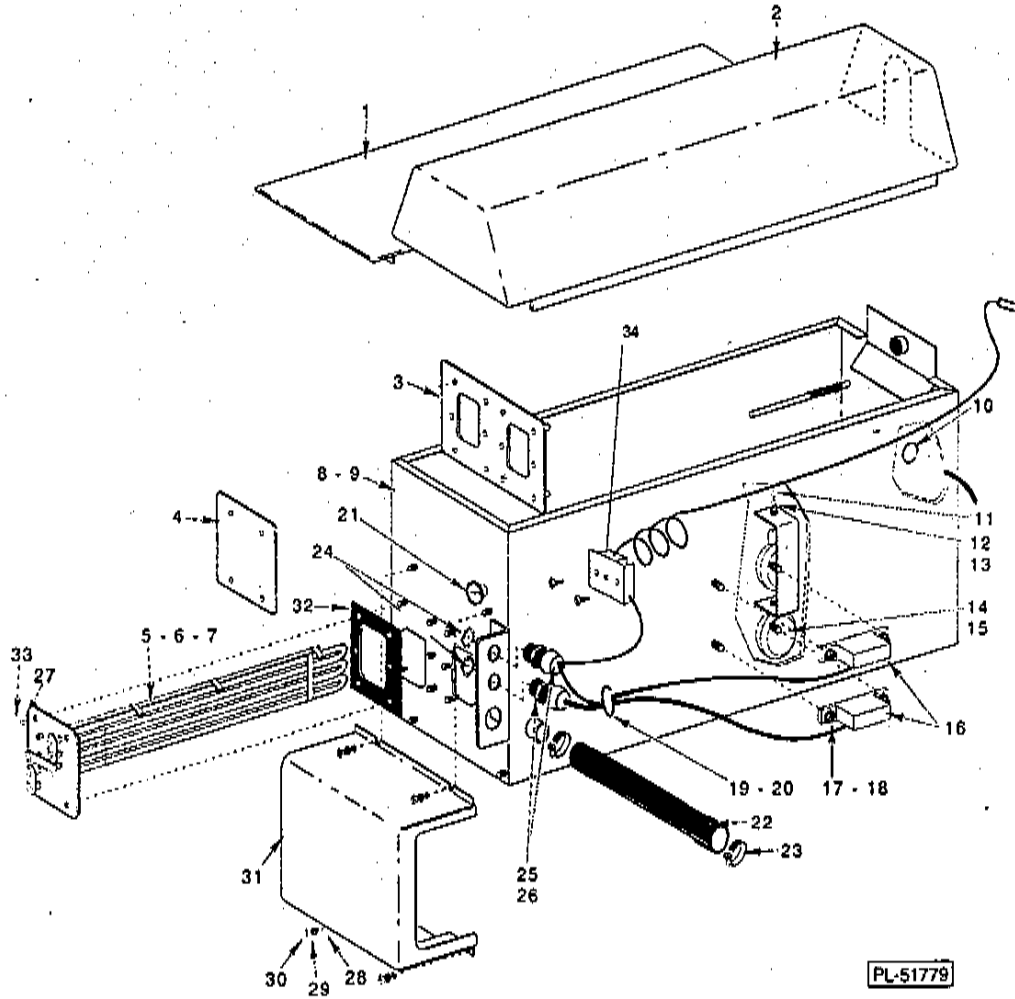

BOOSTER TANK



## BOOSTER TANK

ILLUS	PART NO.	NAME OF PART	AMT.
1	742049	Lid - Booster Tank	1
2	474028	Lid - Booster Tank(Australia)	1
3	743279	Plate - Electric Booster	2
4	742056	Plate - Cover (Use 1 W/7KW or 2 W/14KW)	AR
5	812349-1	Heating Element (240 V., 7000 Watts)	AR
6	812349-2	Heating Element (208 V., 7000 Watts)	1AR
7	743314	Element - Booster Heater (380/415/50/60/3)	1AR
8	742081	Tank - Booster (Australia)	1
9	742097	Tank - Booster	1
10	67500-6	"o" Ring	1
11	NS-11-18	Mach. Nut 10-24 Hex	2
12	WL-6-7	Lockwasher 10 Medium	2
13	WS-23-34	Washer	2
14	122674	Float ASSY.	AR
15	742091	Clip - Float (Use 2 W/7kw OR 14 kw, OR 1 w/Break Tank)	AR
16	474098-3	Switch - Interlock (Use 2 W/7KW or 1 W/Break Tank)	AR
17	NS-31-50	Stop Nut 6-32 Hex(SST)	AR
18	WS-23-21	Washer	AR
19	122575-2	Wire Tie	1
20	NS-47-94	Nut-Lock Special 3/16	1
21	473988	Thermometer	1
22	545674	Hose	AR
23	521687	Clamp - Hose	2
24	FE-24-88	Locknut 1/2	2
25	FE-22-84	Connector - Strain Relief	2
26	FE-8-10	1/2 Gasket Assy	2
27	WL-6-17	Lockwasher 1/4 Medium	6
28	WS-17-6	Washer	6
29	WL-6-17	Lockwasher 1/4 Medium	6
30	NS-15-1	Full Nut 1/4-20 Hex	6
31	742047	Box - Electric Heater	1
32	743312	Gasket - Heater mounting	2
33	NS0-15-1	Full Nut 1/4-20 Hex	4
34	7112001	Thermostat	1

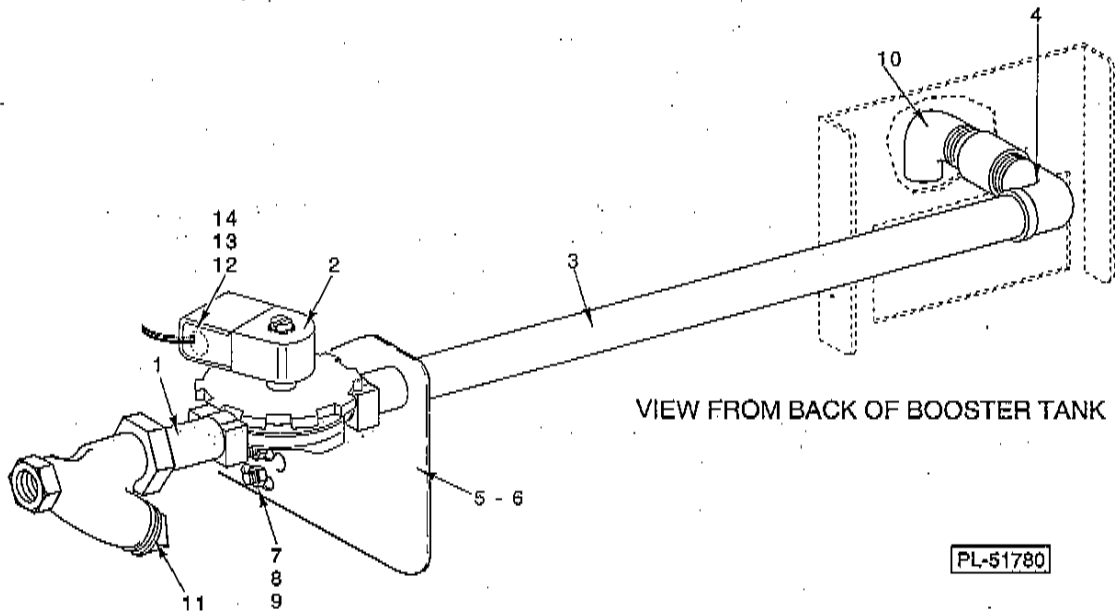

OUTSIDE FILL PIPING

ILLUS.	PART NO.	NAME OF PART	AMT.
PL-51780	1	FP-84-99 Pipe 3/4 x 1 1/4	1
	2	271002-1 Valve - Solenoid (3/4, 110-120 V.)	1
	3	FP-42-59 Pipe 3/4 x 20 1/2	1
	4	FP-15-24 Street L - Pipe 3/4 x 90 Deg. Brass	1
	5	474033 Bracket - Fill Piping (Australia)	1
	6	474002 Bracket - Fill Piping	1
	7	NS-11-18 Mach. Nut 10-24 Hex	2
	8	WS-23-34 Washer	2
	9	WL-6-7 Lockwasher 10 Medium	2
	10	FP-15-24 Street L - Pipe 3/4 x 90 Deg. Brass	1
	11	186922 Strainer - Line 3/4 Brass	1
	12	FE-22-84 Connector - Strain Relief	1
	13	FE-8-10 1/2 Gasket Assy.	1
	14	FE-24-88 Locknut 1/2	1

REPLACEMENT PARTS AM2 DISHWASHER

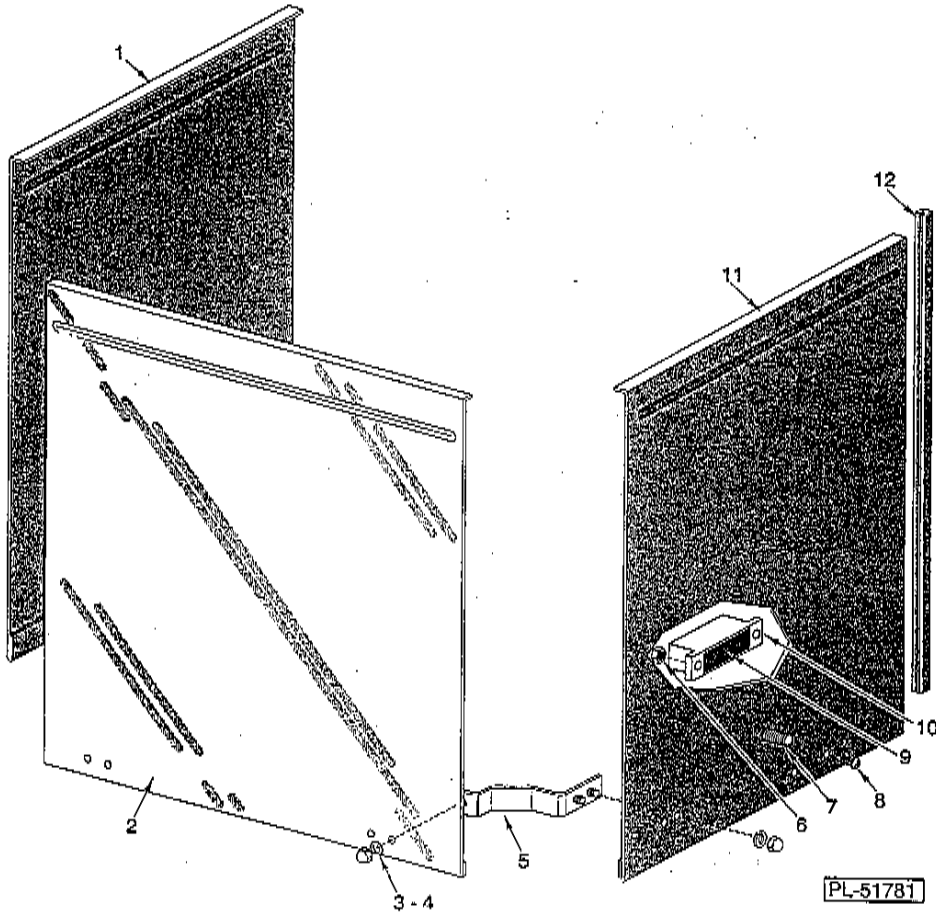

DOOR

ILLUS.	PART NO.	NAME OF PART	AMT.
1	474078	Door (L.H.) .....	1
2	436285	Door Assy. (Front) .....	1
3	NS-25-9	Nut $\frac{3}{16}$ -18 Crown .....	8
4	WL-6-23	Lockwasher $\frac{3}{16}$ Medium SST .....	8
5	185057	Bracket - Door Lift .....	2
6	NS-31-50	Stop Nut 6-32 Hex (SST) .....	2
7	SC-41-17	Cap Screw $\frac{3}{16}$ -18 x 1- $\frac{1}{2}$ Hex Hd. SST .....	2
8	SC-115-26	Mach. Screw 6-32 x $\frac{3}{8}$ Pan Hd. ....	2
9	290160	Magnet .....	1
10	290159	Retainer - Magnet .....	1
11	474077	Door (R.H.) .....	1
12	112378-23	Guide - Door .....	6

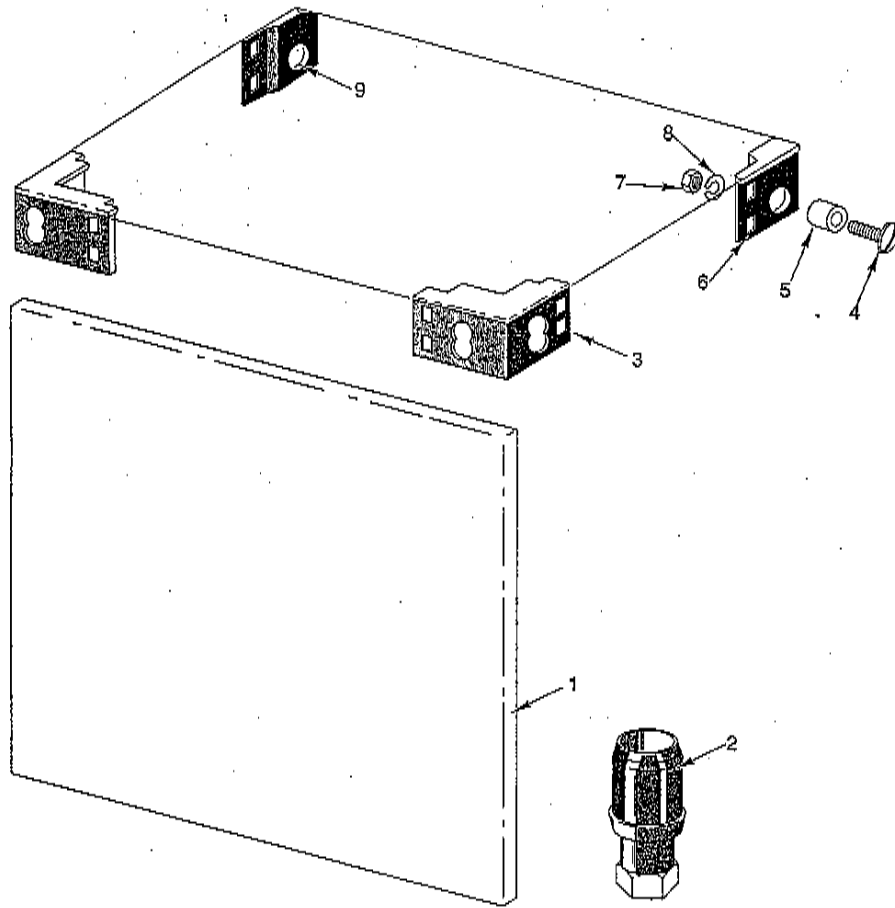

PL-51787

PANEL

PANEL

ILLUS. PL-51787	PART NO.	NAME OF PART	AMT.
1	473977	Panel - Trim (SST) .....	1
2	288946	Foot - Adjustable (1 %)(SST) .....	4
3	119081	Insert - Tank Corner (Front) .....	2
4	SC-53-21	Mach. Screw $\frac{3}{8}$ x 1 $\frac{1}{4}$ Truss Hd. SST .....	6
5	119047	Spacer - Tank & Chamber .....	6
6	119083	Insert - Tank Corner (Right Rear) .....	1
7	WL-6-23	Lockwasher $\frac{3}{8}$ Medium SST .....	10
8	NS-15-11	Full Nut $\frac{3}{8}$ -18 Hex .....	10
9	119082	Insert - Tank Corner (Left Rear) .....	1